



APCO AIR VALVE GUIDE



Air Vent Valve
Series 50



Air Release Valve
Series 55



**Air/Vacuum Valve with
Throttling Device**
Series 140



Combination Air Valve
Series 140C



Air/Vacuum Valve
Series 150



Air Release Valve
Series 200A



Sewage Air/Vacuum Valve
Series 401



**Slow Closing
Combination Air Valve**
Series 1700



**Hydraulically Controlled
Air/Vacuum Valve**
Series 7000

Theory and Use of Air Valves

Engineers: Air Release Valves and Air/Vacuum Valves are essential components to total pipeline design, not accessory items. Without these essential valves, pipeline capacity will be reduced 5 to 10% or more due to air pocket built up in the line. This reduced capacity may go unnoticed because air is an invisible culprit in pipelines.

Efficiency: Not only will pockets of air rob precious line capacity, but entrapped air will also rob precious electrical energy. The pump will have to operate at a higher head to overcome the constricted flow. The elimination of air pockets minimizes the problem and greatly improves the pipeline efficiency.

Economy: Air Release Valves and Air/Vacuum Valves are of fairly simple construction and are not expensive. APCO's years of experience have proven almost without exception that the cost of air valves is less than one percent of the total installed pipeline cost.

Air Release Valves represent low cost insurance for protection of expensive pipelines. Furthermore, the Air Release Valves pay for themselves by eliminating air pockets and maximizing the capacity and operating efficiency of the pipeline. Additionally, protection against pipeline damage will also occur because it is a well known fact that air pockets are a major encouragement to surge pressures and water hammer in a pipeline.

There Are Two Types of Air Valves

1. Air Release Valves

Typically With Small Orifice 1/2" Diameter or Smaller

2. Air/Vacuum Valves

Typically With Large Orifice 1/2" Diameter Or Larger

When These Two Valves Are Combined We Have

3. Combination Air Valves or Double

Orifice Air Valves

Selecting Orifice Sizes for Air Release Valves

For many decades sizing orifices for Air Release Valves has been a mystery. Air entrapped in pipelines is an invisible culprit and no quantitative means exist to determine the precise amount of entrapped air in a flooded transmission pipeline. Also there is no positive means to quantify the volume of liberated air (from the media), which will accumulate and must be vented from each high point. APCO has solved the mystery.

Variables such as: Source of Media – Pressure differential across the pump – operating pressure – plus pressure/temperature fluctuations along the transmission line, will dictate the amount of air released from the media accumulating at each high point.

Air Release Valves discharge air (which has accumulated inside the valve) from the high point. Generally, Air Release Valves are not constantly discharging air during system operation, but only discharge intermittently as air accumulates at the high point.

Based on the preceding and more than 75 years application experience, APCO developed and recommends the following criteria be used:

1. Use 2% of the media volume divided by the number of high points as the minimum amount of entrapped air.
2. Consider this volume as the basis for the amount of air to be discharged from each high point.

$$\text{AMOUNT OF AIR TO BE DISCHARGED, CFM} = \text{FLOW CAPACITY IN GPM} \times \frac{2\%}{7.48} \text{ or } \frac{\text{FLOW CAPACITY IN GPM}}{374}$$

(As Defined and Recommended)

3. Upon determining the operating pressure of the system, refer to the APCO Venting Capacity Graph for Air Release Valve Orifice then Table of Orifice Sizes to select Model and Size.

Example: A pipeline actual flow capacity of 18,700 GPM and operating at 150 psi. Amount of air to be discharged = $\frac{18,700}{374} = 50$ CFM

Using the Venting Capacity Graph for Air Release Valves, 50 CFM and 150 psi will intersect the 3/16 orifice curve.

Then, on the Table of Orifice Sizes, Model 200A with 3/16 orifice can be selected with the appropriate inlet size.

Note: If the intersection of the Venting Capacity, (CFM) and Operating Pressure (PSI) lies between orifice curve, use the larger orifice.

How to Select and Size an Air Release Valve When a Specific Venting Capacity is Required

- A. Enter graph with pressure in the system and the venting capacity required.
- B. Read off nearest orifice diameter to intersection of pressure and capacity lines on graph.
- C. Enter table next page with orifice diameter and select valve which can use this orifice diameter at the pressure involved.

Venting Capacity Graph For Air Release Valves

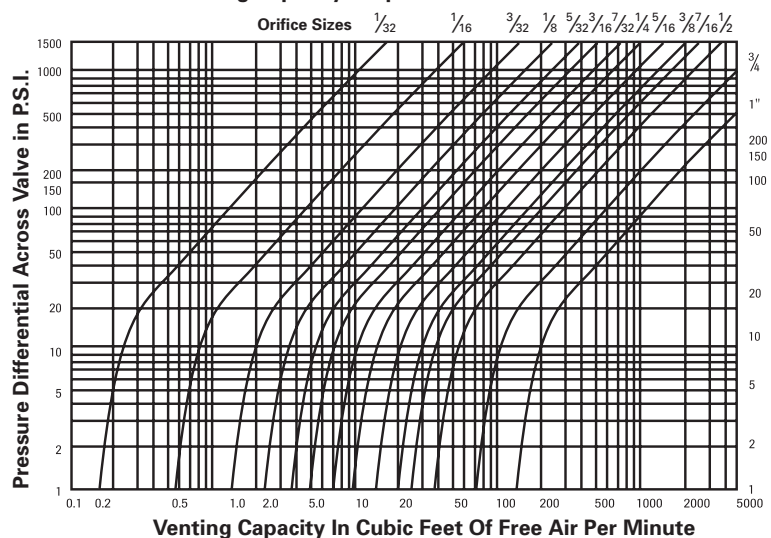

1. Air Release Valves

Air Release Valves are hydro-mechanical devices which automatically vent small pockets of air as they accumulate at high points in a system while the system is operating and pressurized. By understanding problems associated with air pockets in a system we can appreciate that Air Release Valves (ARV) are devices ideally suited to eliminate those problems. As a function of physics, entrained air will settle out of the liquid being pumped and collect at high points within the system. If provisions are not made to remove this air from high points, pockets of air will collect and grow in size. Air pocket growth will then gradually reduce the effective liquid flow area, creating a throttling effect as would a partially closed valve. The degree which flow is reduced and some ensuing problems are described in the following.

Often the velocity of the liquid will remove air bubbles if the pipeline slopes upward to lodge at a high point. But, if the pipeline is fairly flat, the ceiling of the pipe is very rough or the pipeline slopes downward, the velocity may not be sufficient to keep the air pockets (bubbles) moving. Additional Air Release Valves (ARV's) must be installed to prevent this 'throttling' effect.

In extreme cases it is possible for an enlarging pocket of air collecting at a high point within a system to create an air block to a degree where the flow of fluid virtually stops. In this severe case an air problem is easily detected and installation of ARV's at the high points will remove the restrictive pockets of air to restore system efficiency.

Another serious consequence is sudden movement of these air pockets causing rapid velocity changes of the liquid being pumped. The dynamics involved in velocity change can be substantial, resulting in high pressure surges and other destructive phenomena in the pipelines.

Therefore, problems with air entrapped in a system can range from mild, but costly, to severe and destructive. The design engineer should prevent accumulation of air by installing ARV's on all high points of a system.

Air Release Valve Operation

The valves installed on a high point of the system will fill with liquid, shut off, and be subjected to system pressure. During system operation small particles of air will separate from the liquid and enter the valve. Each particle of air will displace an equal amount of the liquid within the valve and lower the liquid level relative to the float. When the liquid level lowers the float will drop. This action opens the valve orifice and allows the air which has accumulated in the upper portion of the valve to be released to atmosphere. As air is released, the liquid level within the valve once again rises, lifting the float and closing the valve orifice. This cycle repeats itself as often as air accumulates in the valve.

The ability of the ARV to open and release accumulated air under pressure is achieved through the use of a leverage mechanism. When the float is no longer buoyant, this mechanism (plus the weight of the float) produces a greater force to open the valve than to hold the valve closed. Accordingly, the higher the system pressure the smaller the orifice diameter must be to allow the valve to open and release accumulated air. Conversely, with the same valve and a lower system pressure, a larger diameter orifice can be used to release accumulated air.

Note: ARV's are intended to release air as it accumulates at high points during system operation. They are not normally recommended for vacuum protection nor to vent large volumes of air when filling large diameter pipelines, because inherently ARVs have small orifices, usually less than 1/2" diameter – Air/Vacuum Valves have much larger orifices for this purpose. However, ARV's will permit small quantities of air to re-enter under negative conditions and if objectionable, specify ARV's with a vacuum check.

Ask for APCO Computer Software Programs for sizing and specifying your valves.

Table of Orifice Sizes

NOTE: Please specify if pressures are below 20 psi.

Model	Inlet Size	Maximum Orifice Sizes Which Can Be Used With The Following Pressures													
		10	25	50	75	100	125	150	200	250	300	500	800	1500	
50	.5", .75", 1" 12.7, 19.05, 25.4	.094" 2.4	.094" 2.4	.094" 2.4	.094" 2.4	.094" 2.4	.094" 2.4	.094" 2.4	.062" 1.6	.062" 1.6	.062" 1.6	X	X	X	
55	.5" 12.7	.094" 2.4	.094" 2.4	.094" 2.4	.094" 2.4	.094" 2.4	.094" 2.4	.094" 2.4	X	X	X	X	X	X	
65	.75" 19.05	.219" 5.6	.219" 5.6	.219" 5.6	.219" 5.6	.125" 3.2	.125" 3.2	.125" 3.2	X	X	X	X	X	X	
200A	1", 2" 25.4, 50.8	.312" 7.9	.312" 7.9	.312" 7.9	.25" 6.4	.187" 4.8	.187" 4.8	.187" 4.8	.156" 4	.156" 4	.156" 4	X	X	X	
200	2" 50.8	.5" 12.7	.5" 12.7	.5" 12.7	.5" 12.7	.375" 9.5	.375" 9.5	.375" 9.5	.219" 5.6	.219" 5.6	.219" 5.6	X	X	X	
205	2" 50.8	X	X	X	X	.5" 12.7	.375" 9.5	.375" 9.5	.219" 5.7	.219" 5.7	.219" 5.7	.219" 5.7	.125" 3.2	X	
206	2" 50.8	X	X	X	X	X	X	X	X	X	X	X	X	.094" 2.4	
207	6" 152.4	1" 25.4	1" 25.4	1" 25.4	1" 25.4	1" 25.4	1" 25.4	1" 25.4	.75" 19	.75" 19	.75" 19	X	X	X	
400	2", 3", 4" 50.8, 76.2, 101.6	.312" 7.9	.312" 7.9	.312" 7.9	.25" 6.4	.25" 6.4	.25" 6.4	.25" 6.4	.187" 4.8	.156" 4	.156" 4	X	X	X	
450	2", 3", 4" 50.8, 76.2, 101.6	.5" 12.7	.5" 12.7	.5" 12.7	.5" 12.7	.5" 12.7	.5" 12.7	.5" 12.7	.437" 11	.437" 11	.437" 11	X	X	X	

Inch
Millimeter

Standard Orifices Are In Gray



Compound Lever
APCO Series #200A

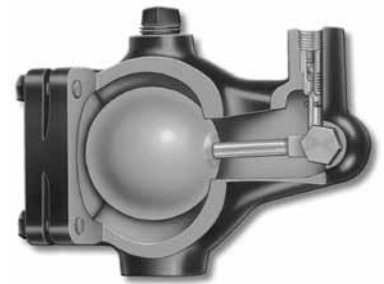

Simple Lever
APCO Series #55



Simple Lever Seat Detail

2. Air/Vacuum Valves

An Air/Vacuum Valve (AVV) is float operated, having a large discharge orifice equal in size to the valve inlet. This valve allows large volumes of air to be exhausted from or admitted into a system as it is filled or drained.

Used on pipelines, the following conditions would prevail:

Prior to filling, a pipeline is thought to be empty, but this is not true. In reality it is filled with air. This air must be exhausted in a smooth uniform manner to prevent pressure surges and other destructive phenomenon from occurring in the pipeline.

Additionally, air must be allowed to re-enter the pipeline in response to a negative pressure to prevent a potentially destructive vacuum from forming. Even in those instances where vacuum protection is not a primary concern, air re-entry is still essential to efficiently drain the pipeline. At locations where column separation is anticipated an Air/Vacuum Valve will allow air to enter, preventing a destructive vacuum from forming which is as damaging as pressure surges.

Air/Vacuum Valve Operation

As the pipeline is filled, air is exhausted to atmosphere through an AVV mounted on each high point. As air is exhausted from the pipeline, water will enter the valve and lift the float to close the valve orifice. The rate of air exhausted is a function of pressure differential, which develops across the valve discharge orifice. This pressure differential develops as water filling the pipeline compresses the air sufficiently to give it an escape velocity equal to that of the incoming fluid. Since the size of the valve controls the pressure differential at which the air is exhausted, valve size selection is a very important consideration.

Any time during system operation, should internal pressure of the pipeline approach a negative value due to column separation, draining of the pipeline, power outage or pipeline break, the float will immediately drop away from the orifice and allow air to re-enter the pipeline. Air re-entry during water column separation will prevent a vacuum. This protects the pipeline against collapse. The size of the AVV will dictate the degree to which a vacuum is prevented, therefore correct valve size selection is necessary. The AVV, having opened to admit air into the pipeline in response to a negative pressure, is now ready to exhaust air again. This cycle will repeat as often as necessary.

During system operation and while under pressure, small amounts of air will enter the AVV from the pipeline and displace the fluid. Eventually, the entire AVV may fill with air, but it will not open because the system pressure will continue to hold the float closed against the valve seat. To reiterate, an AVV is intended to exhaust air during pipeline fill and to admit air during pipeline drain. It will not open and vent air as it accumulates during system operation – Air Release Valves are used for this purpose.

See Bulletin 601

Characteristics of Air Flow Through an Air/Vacuum Valve Orifice

Linear velocity of air, discharged through the orifice of an Air/Vacuum Valve increases as pressure differential across the orifice increases, until reaching a maximum velocity of approximately 300 feet per second. This maximum air velocity occurs at about 7 psi and remains a constant thereafter, regardless of further increase in the pressure.

Explanatory Note: Unlike liquids, the volume of air that fills one cubic foot at atmospheric pressure will occupy a progressively lesser volume as its pressure increases.

The amount of air actually expelled through the orifice continues to increase indefinitely as the pressure increases. While there is no further increase in the escape velocity beyond 7 psi approximately, the air escaping at this velocity itself becomes progressively denser and represents a greater amount when expressed in cubic feet at atmosphere, ie. C.F.F.A.M.

To accommodate this condition, flow of air is always referred to in cubic feet of free air per minute (C.F.F.A.M.) even though the air under consideration is usually at some other pressure than atmosphere.

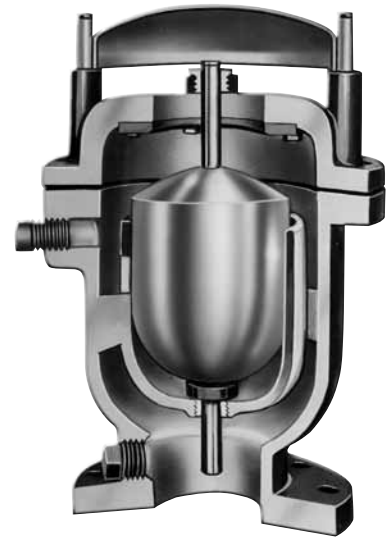

4" Thru 30"
APCO Series #150



1/2" Thru 3"
APCO Series #140

3. Combination Air Valves

As the name implies, Combination Air Valves (CAV) have operating features of both Air/Vacuum Valves and Air Release Valves.

These valves are also called Double Orifice Valves. These valves are installed on all high points of a system where it has been determined Air/Vacuum and Air Release Valves are needed to vent and protect a pipeline. Generally it is sound engineering practice to use CAV's instead of simple purpose Air/Vacuum Valves.

CAV's are available in two body styles – (1) a single body combination (2) a custom built combination (CCAV) with two (2) bodies. The single body CAV is used where compactness is preferred and/or where risk of tampering exists due to accessibility of the installation. This style is available 1" thru 8" sizes.

The custom built CAV is an Air/Vacuum Valve piped with a shut-off valve to an Air Release Valve. This CAV has greater versatility than the single body style because a variety of Air Release Valves with a wide range of orifices with higher operating pressures can be used. This style is available in 2" thru 30" sizes. When doubt exists to use an Air/Vacuum Valve or a CAV at a particular location, it is recommended the CAV be used for maximum pipeline protection.

For pipeline economy and operating efficiency, we highly recommend pipelines be laid to grade where possible, instead of merely following the natural terrain. The result will be smoother less turbulent flows of liquid, fewer high points where air will collect, so fewer air valves are needed.

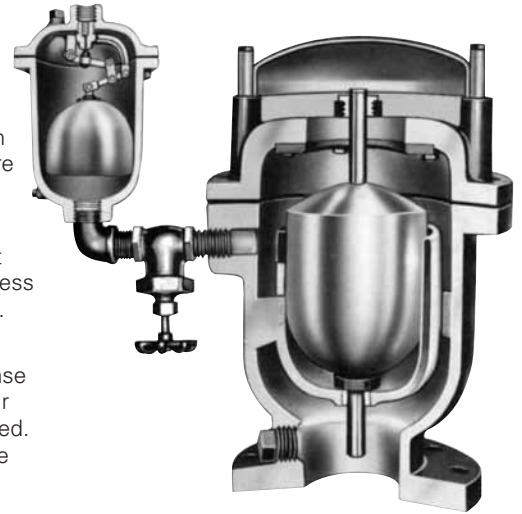

CUSTOM DUPLEX BODY COMBINATION
APCO Series #1800

Combination Air Valves Operation

Combination Air Valves (CAV's) prevent accumulations of air at high points within a system by exhausting large volumes of air as the system is filled and releasing accumulated pockets of air while the system is operational and under pressure. CAV's also prevent potentially destructive vacuums from forming. They admit air into the system. This will occur during power outages, water column separation or sudden rupture of the pipeline. Additionally, these valves allow the system to be easily drained because air will re-enter, as needed

Potentially damaging vacuum conditions and pressure surges induced by air can be avoided and maximum pipeline efficiencies attained through proper understanding and application of air valves.

General Air Valve Application

To apply air valves, first make the following determinations:

1. Where should air valves be installed on pipelines?
2. What style air valves should be used?
3. What size air valves are required?

Answers

1. AVV's or CAV's should be installed on all pipeline high points and changes in grade.
2. CAV's or ARV's should be installed on those high points where it is possible for air pockets to accumulate. Also ARV's should be installed on high points and at intervals of 1,500 to 2,500 feet on long horizontal runs lacking clearly defined high points.
3. Also installing manways at intervals in larger size pipelines provides an excellent point to install ARV's.
4. Size using APCO Air Valve Slide Rule Computer or APSLIDE software program.

See Bulletin 623

STANDARD SINGLEBODY COMBINATION
APCO Series #140C

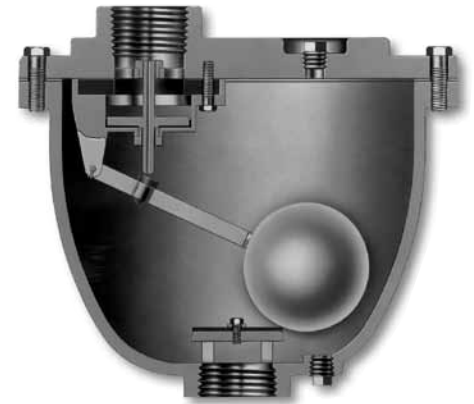

Typical Pipeline Showing its Hydraulic Gradient & the Position of Necessary APCO Air Valves

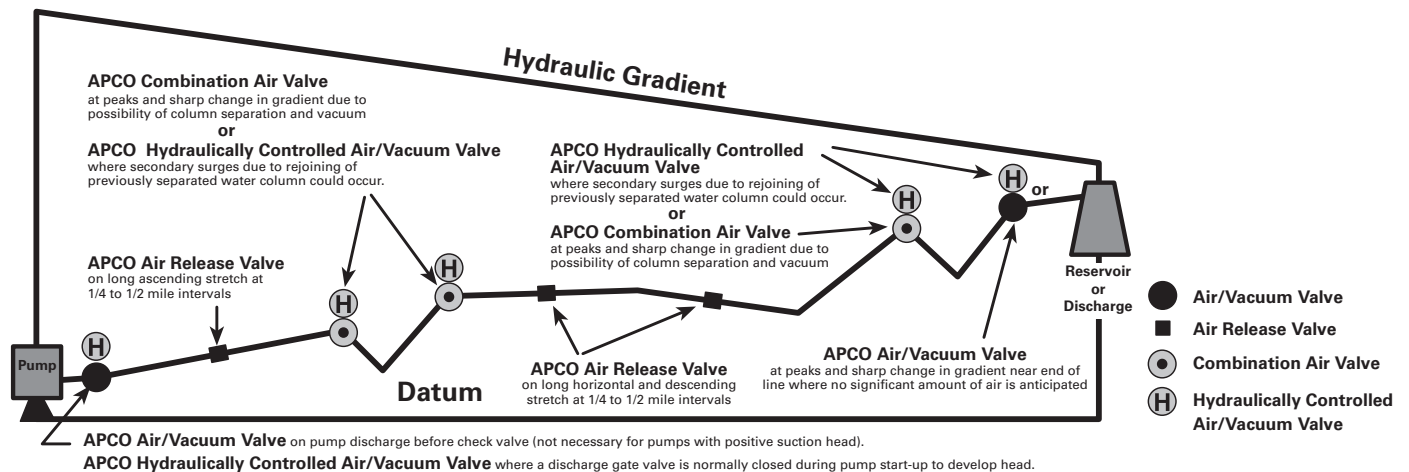

Special Service Air Valves

Air Release Valves & Air/Vacuum Valves for Sewage Lines

APCO air valves for sewage operation are identical to the standard air valves. They differ only in appearance, with the bodies being considerably longer in height.

The elongated bodies serve to minimize the problem of clogging by the use of a long float stem, which creates an air pocket to prevent the sewage from fouling up the top mechanism.

For ease of maintenance, Back Flushing Attachments are recommended with the valves as shown in the photos. Once installed, the valves should be inspected at least once a year to determine the need to backflush. The test to make this determination is simple and not time consuming. All that needs to be done is shut off the inlet valve and open the blow off valve. If the fluid drains from the valve body rapidly, flushing is not required.

When installing Sewage Air Valves on your pipeline the same criteria applies as with the standard air valves. However, the potential for air entrapped with sewage pipelines is even greater than that found in water lines because sewage media generates large quantities of gases. Therefore it is recommended that each high point be protected with an automatic Sewage Air Release Valve.

Combination Sewage Air Release & Air/Vacuum Valves also available.

See Bulletin 400

Slow Closing Air Valve

The APCO Slow Closing Air Valve is designed to eliminate critical shock conditions on installations where operating conditions cause a regular air valve to slam shut.

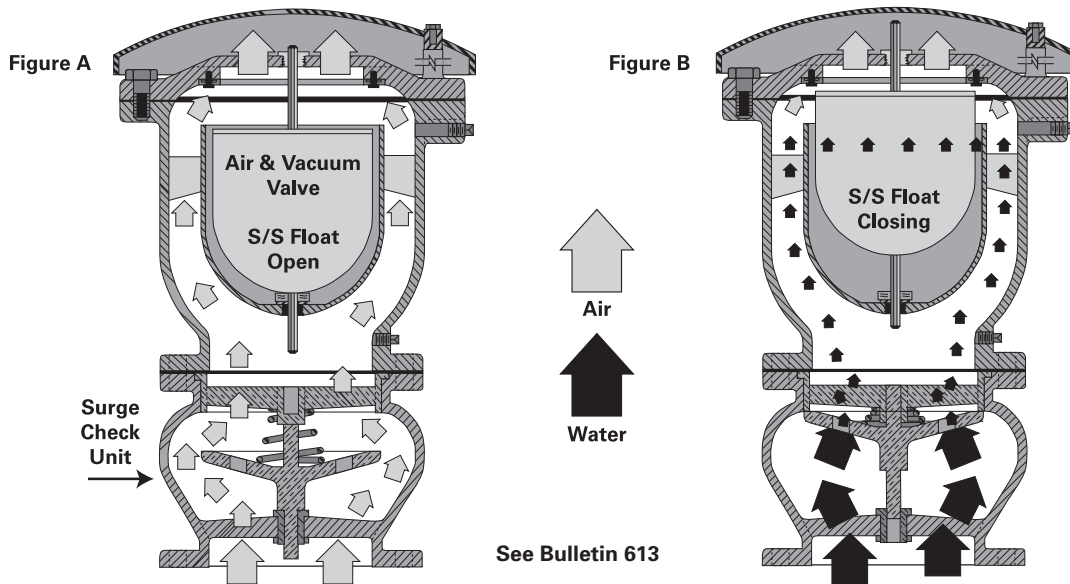

See Bulletin 613

How it Operates

The APCO Slow Closing Air Valve consists of a standard Air/Vacuum Valve mounted on top of a Surge Check Unit.

The air valve operates in the normal fashion allowing air to escape freely. (Figure A)

The Surge Check Unit operates on the interphase between the kinetic energy in the relative velocity flow of air and water. Air passes through unrestricted but when water rushes into the Surge Check Unit, a disc closes and reduces the rate of water flow into the air valve by means of throttling holes in the disc. (Figure B)

This ensures normal gentle closing of the Air/Vacuum Valve regardless of the initial velocity flow involved. This also minimizes pressure surges when the valve closes.

As soon as the air valve is closed, the pressure on both sides of the Surge Check Unit disc equalizes and the disc automatically

returns to its open position. This means the air valve surge check does not need an incipient vacuum to open, but can open at any time the water level drops and line pressure approaches atmospheric level. This immediately allows the full re-entry flow of air into the pipe line.

Where to Use it:

1. At high points in pipelines where the hydraulic gradient and flow conditions are such that a negative pressure can possibly form.
2. At high points on sections of pipeline having water velocities in excess of 10 F.P.S.
3. Adjacent to any quick closing valve in a pipeline such as a check or gate valve where a vacuum can be formed upon closure.
4. On the discharge of large turbine pumps (i.e., over 1000 gpm) between the pump and the check valve.

Special Service Air Valves



Hydraulically Controlled Air/ Vacuum Valve

Used for positive pipeline protection against damaging pressure surges. The operating principle of this valve is the same as the conventional Air/ Vacuum Valve with one exception – Hydraulically Controlled Air/ Vacuum Valves are normally open (because the heavy cast float is not buoyant) and slowly close after spilling a regulated volume of water to minimize a pressure surge. This valve provides excellent pipeline protection against primary and secondary surge pressures which usually occur when filling or draining a pipeline. The closing time of this valve is variable and adjustable by means of a self enclosed hydraulic control system.

Series 7000

See Bulletin 7000

Syphon Air Valve (Make And Break)

Syphon Air Valves are a unique type of Air/Vacuum Valve incorporating a paddle which hangs down into the main pipeline flow stream. The valve will allow a syphon flow to be developed and maintained. Subsequently should the syphon flow reverse, the paddle swings in reverse causing the float to drop and break the syphon. The APCO Syphon Air Valve requires no electrical connections or regular maintenance and is ideally suited for remote outdoor environments. In recent years with the emphasis on energy conservation, consulting engineers for water and waste water often consider pumping by means of a syphon loop. APCO Syphon Air Valves are ideally suited for this application. Solenoid valves for small diameter syphons, or pneumatically operated butterfly valves for large diameter syphons, may also be adapted for this application, but installation and maintenance is complicated and cumbersome. For example, power lines and air lines must be installed to operate these valves. An air compressor is also needed. APCO Syphon Air Valves are mechanically operated, requiring no auxiliary power. They merely respond to flow in either direction, to make the syphon or break it. Maintenance is virtually non-existent.

Series 5200 available in sizes 3"-16" for syphons up to 60" in diameter.

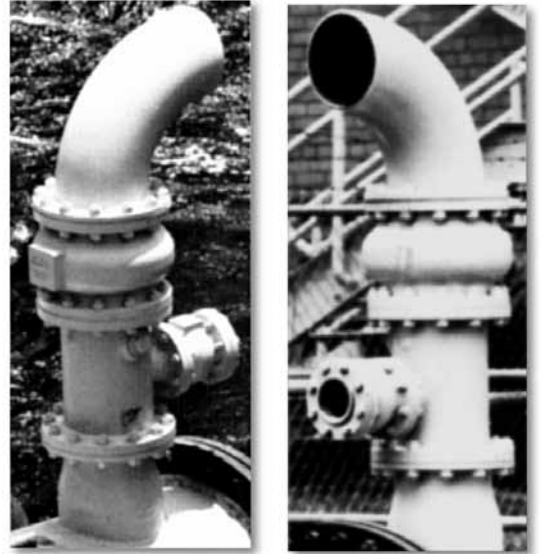

Vacuum Relief/Air Inlet Valves

Vacuum Relief/Air Inlet Valves are large orifice one way valves. They permit air to enter the pipeline or system (to break the vacuum), but no air escapes when the system pressure returns to positive.

Vacuum Relief/Air Inlet Valves are normally closed spring-loaded valves that will respond to a vacuum in the pipeline. The Vacuum Relief/Air Inlet Valve is designed to open with a minimal 1/4 PSI pressure differential across the orifice. Higher or lower settings are available from the factory.

Vacuum Relief/Air Inlet Valves are available in combination with any of the APCO Air Release Valves (Bulletin 600) to permit full flow air into the pipeline and slow air out of the pipeline through the Air Release Valve orifice.

Series 1500.

See Bulletin 1500

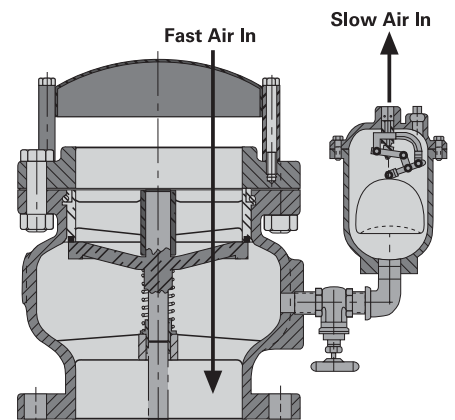
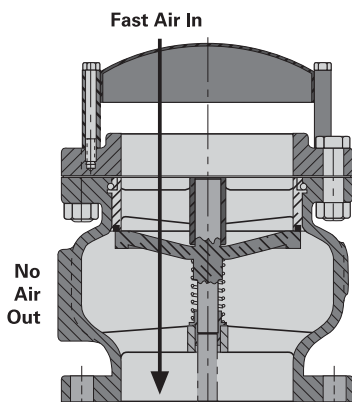

Pump Protectors



Pump protectors are an inexpensive way to protect a very expensive Centrifugal Pump from damage due to loss of prime. The Pump Protector is made up of two components; an Automatic Air Release Valve and a Water Level Control Switch. The Automatic Air Release Valve allows air from the suction line and pump volute to be vented. The Water Level Control Switch senses the water level rising – indicating the pump is primed or the level is falling. When indicating loss of prime the Pump Protector will make or break the electrical circuit to the pump. Additionally a horn or a warning light may be provided. Pump Protectors are low in cost, and installation and maintenance are simple.

Series 2123P.

See Bulletin 645.

Air Valves for Vertical Turbine Pumps

Air Valves for Vertical Turbine Pumps are essential to prevent large volumes of air entering the water system each time the pump is started and to break a vacuum when the pump stops. Air Valves for Vertical Turbine Pumps are basically Air/Vacuum Valves. However, additional features such as an internal Water Diffuser or external Air Throttling Device or inlet water Surge Check are essential to suit these valves for use on Vertical Turbine deep well pumps. Without these features the basic Air/Vacuum Valve will most likely spill substantial amounts of water before shutting off, or it may not shut off at all. These features will prevent premature closure due to the air in the suction column being saturated with moisture.

See Bulletins 586 & 601

Installation

Install the Air/Vacuum Valve on the discharge side of the pump as close to the Check Valve as possible. An APCO Check Valve is recommended.

See Bulletin 769

It is recommended an APCO Shut Off Valve be installed below the Air/Vacuum Valve for inspection and future maintenance.

Benefits of Throttling Device on Turbine Service

A throttling device permits the operator to restrict the flow of air escaping from the valve and establish a back-pressure slowing the rising column of water. The surge in the line is thereby reduced. This action results in a smoother, trouble-free operation saving maintenance money. A throttling device is available on APCO Air/Vacuum Valves from the 1/2" through the 6" size.

See Bulletin 586

Special Conditions: Or High Service Pumps (Above 150 PSI)

When pump discharge velocities are 10 F.P.S. or more, use a Surge Check Unit with Air/Vacuum Valves to minimize water hammer. Pipe the discharge outlet back to the well to muffle noise and contain spillage.

See Bulletin 613

When the pump is operating against a positively closed discharge valve, use a Hydraulically Controlled Air/Vacuum Valve to prevent any surge from occurring before the discharge valve opens.

See Bulletin 7000

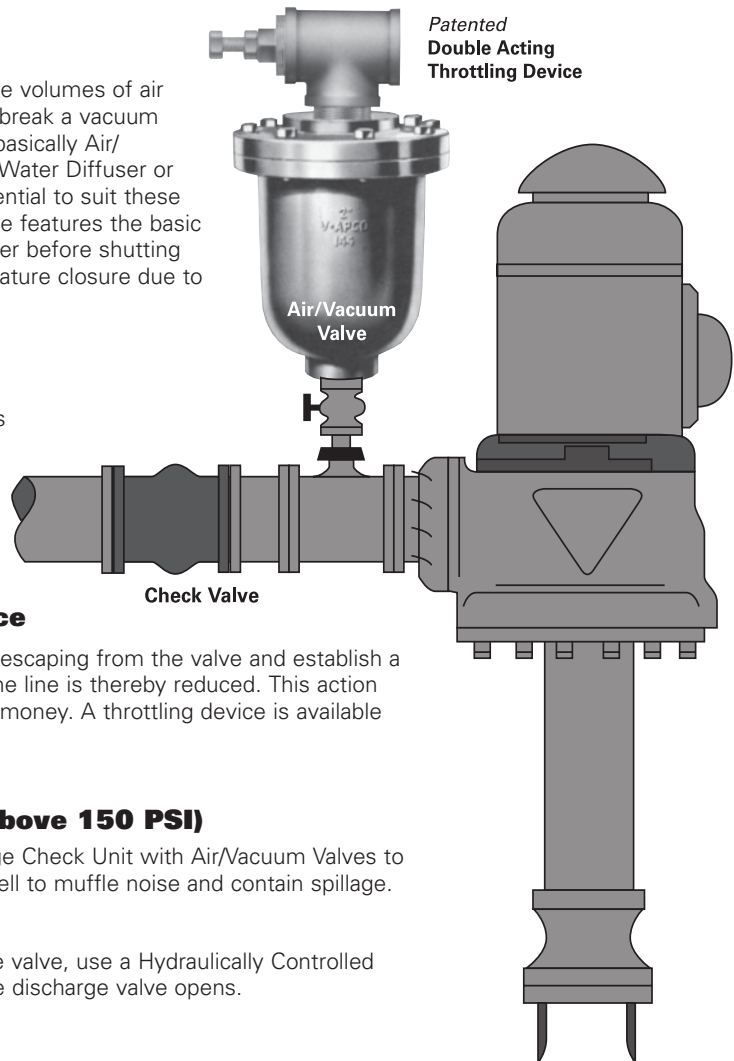

Typical Air Valve Applications

Air Release Valves for Centrifugal Pumps

An Air Release Valve mounted on the volute of a pump as shown in the illustrations below, will rid the pump of entrapped air. The Air Release Valve will be furnished upon request with a Vacuum Check, which will permit air to pass out, but not in. This is especially desirable with volatile fluid. Model 55 is standard with a Vacuum Check. Vacuum Check is optional on all other Air Release Valves.

See Bulletin 600

Check the tapped hole on the volute of the pump. If $\frac{1}{2}$ " or larger, select a valve with same inlet size from table, and mount per Figure A. If $\frac{3}{8}$ " or less, use $\frac{1}{2}$ " #55 valve mounted on suction side per Figure B. Check the table to see if the valve selected can handle the maximum pressure involved. When ordering specify working pressure.

Models 50 & 55 factory mutual (FM) approved and underwriters (UL) listed.

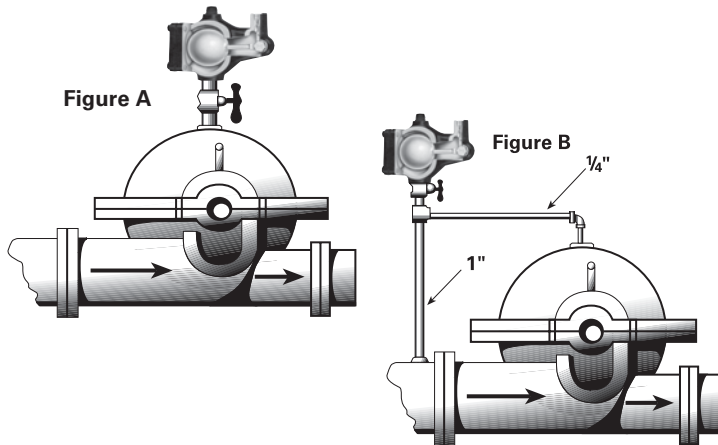

Valve Model Number	Inlet Size NPT	Standard *Material	Maximum Pressure
50	$\frac{5}{8}$ ", $\frac{75}{64}$ ", 1" 12.7, 19, 25.4	Cast Iron	300 PSI
55	$\frac{5}{8}$ " 12.7	Cast Iron	150 PSI
65	$\frac{75}{64}$ " 19	Cast Iron	150 PSI
200A	1" 25.4	Cast Iron	300 PSI
200	2" 50.8	Cast Iron	300 PSI
205	2" 50.8	Cast Iron	800 PSI
206	2" 50.8	Cast Iron	1500 PSI

Inch
Millimeter

* Other materials, such as Stainless Steel, Steel, Bronze, etc., are available.

Air Release Valves for Fuel Transfer Systems

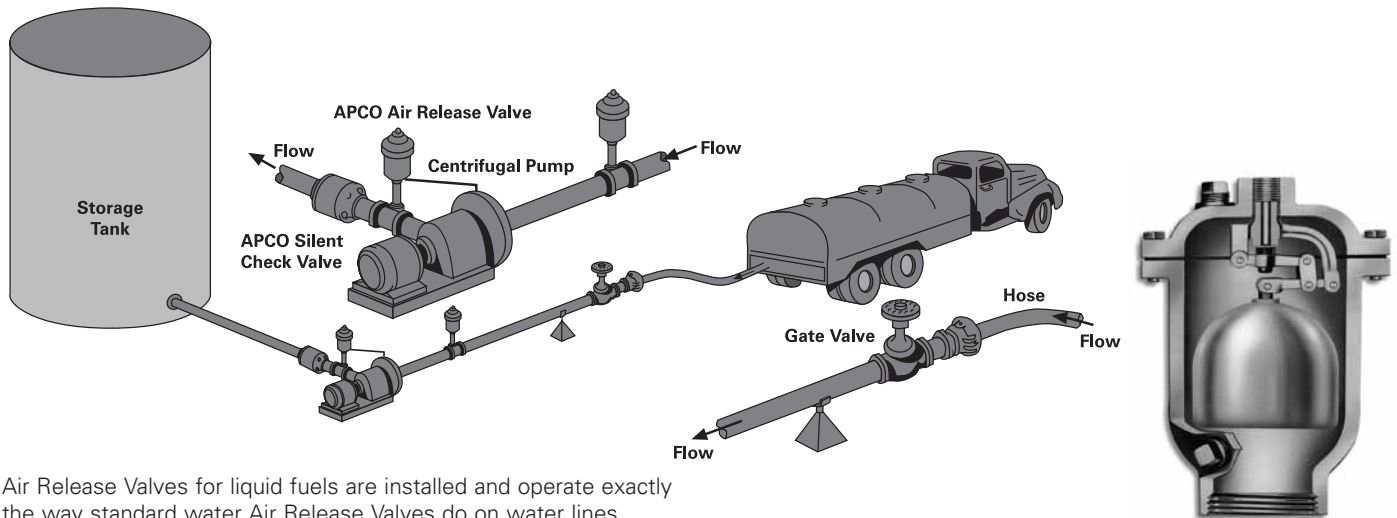

Air Release Valves for liquid fuels are installed and operate exactly the way standard water Air Release Valves do on water lines. However, one main difference does exist in the design of the float. The float of the Fuel Air Release Valve is designed to have greater buoyancy than the float in a standard Water Air Release Valve. Additional buoyancy is essential to overcome the lower specific gravity of the various liquid fuels, to ensure tight shut off, and to prevent dangerous spilling of fuels from the Air Release Valve.

Caution: Standard Water Air Release Valves must not be used on fuel lines. When ordering or specifying APCO Air Release Valves for fuel service, add the suffix "F" to the model number of the valve, ie; the model 200 Air Release Valve becomes model 200F; the model 55 Air Release Valve becomes the model 55F, etc.

See Bulletin 6510

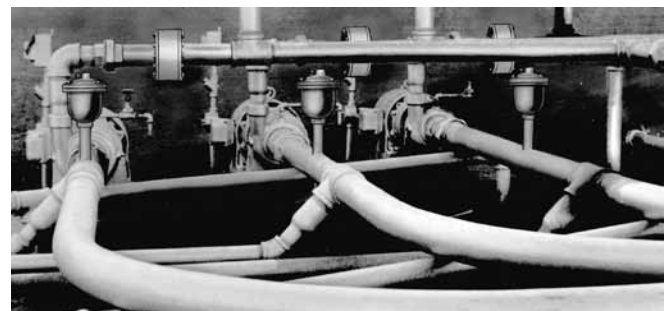

Air Eliminators

Well Point Systems

In well point and similar systems which are subject to large irregular slugs of air, the Air Eliminators are excellent because of their capacity to trap and hold the slug of air and then discharge it into the atmosphere. Where there is a negative pressure in the line it is necessary to attach a vacuum line to the valve orifice. This insures that any air which collects in the valve will be drawn off when the valve opens.

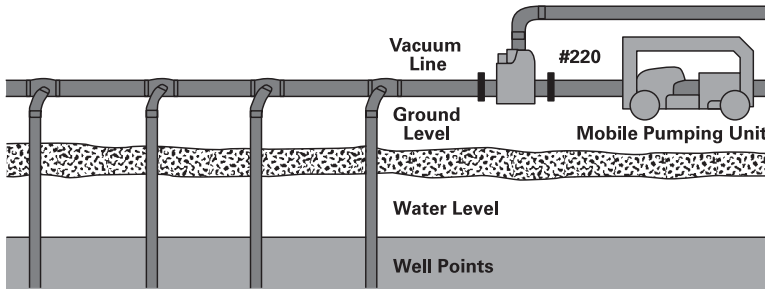

Application:

Air Eliminators are especially valuable for use on gasoline and oil metering systems, where it is essential to eliminate any air or vapor in the fluid, before it reaches the meter, thus preventing a false reading and increased cost to the buyer.

Available in sizes 2" thru 12" constructed to A.S.M.E. code standards for maximum protection.

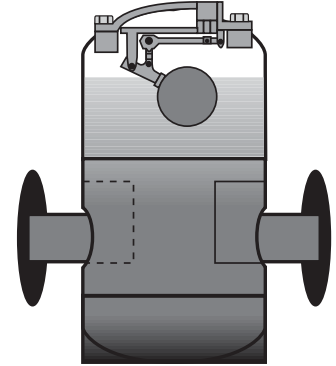

Air Release Valve for Pressure Filters

Pressure filter tanks are used by many municipalities and industrial water systems.

Every pressure filter needs an Air Release Valve to release air entrapped in normal operation (in some systems air is injected into the water for the aeration process).

Many different APCO valves have been used successfully for this purpose, but we recommend the APCO 1/2" - No. 55 Air Release Valve as being most suitable for filter service.

The Air Release Valve should be mounted on top of the filter tank and in systems where a battery of filters are used. Each tank should have its own air valve.

In filter systems serviced by a deep well turbine pump, an APCO Turbine Air Valve and an APCO Silent Check Valve installed adjacent to the pump will provide a fully protected system.

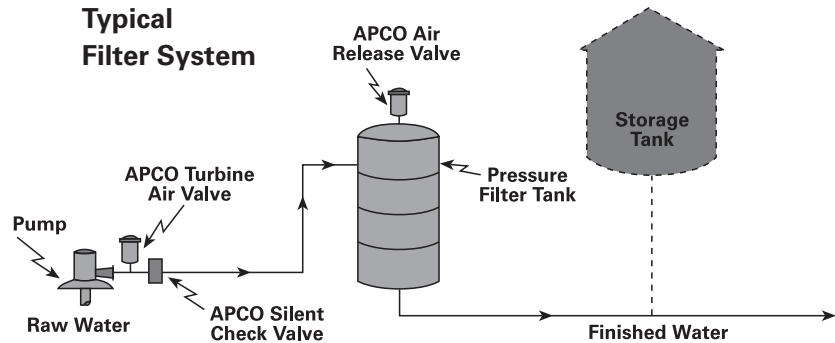

See Bulletin No. 586 & 640



50 Air Vent Valve

Typical Air Valve Applications

At all high points in a water line – whether domestic water, hot water, or cold water for cooling – air will accumulate and must be released. This is also true where a large amount of air is encountered – as with the air injection of chlorine into a water system. Air will accumulate and must be released.

The APCO-50 Air Vent Valve installed at these high points will release the accumulated air to ensure unrestricted flow of the water and minimize the problem of annoying and sometimes damaging water hammer.

The standard APCO-50 Air Vent Valve with 3/32" orifice should provide more than adequate venting for these installations.

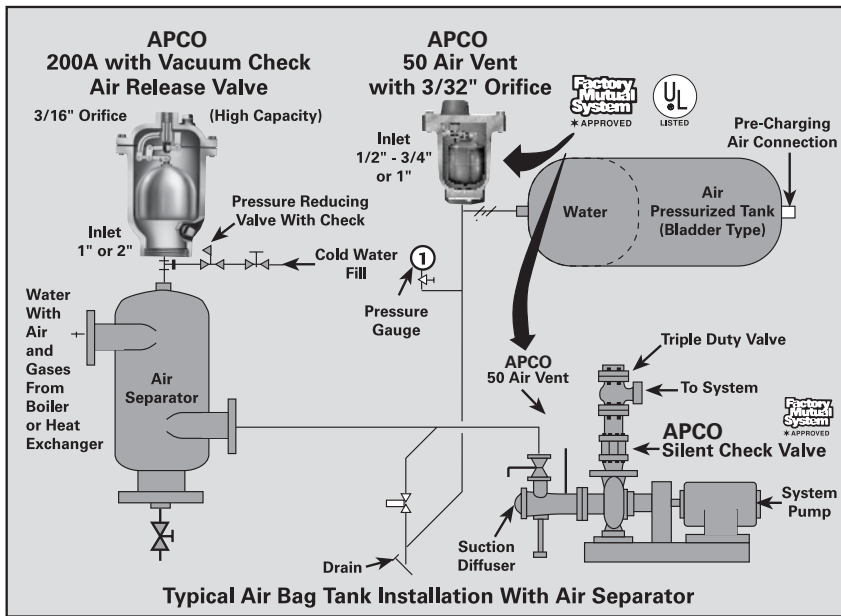

See Bulletin 50

Air Release Valves for Hydro-Pneumatic Water Tanks

APCO Model 55 Air Release Valves are used on hydro-pneumatic water tanks. To automatically prevent the tank from becoming air-bound or water-logged.

APCO Model 54 Pressure Relief Valves protect water-air balance in hydro-pneumatic tanks during periods of excessive demands.

The vast majority of buildings over two stories utilizing a central hot water and chilled water heating/cooling system, require reliable positive shut-off air vents and high venting capacity Air Release Valves. This application demands rugged long lasting type APCO air valves.

The cheap variety – throw away type vents - don't measure up to the requirements of this application.

The air valves ideally suited to this application are the APCO Model 200AVC and Model 50. The purpose of the 50 Air Vent is to rid the piping system of small pockets of air which accumulate at all high points that would otherwise restrict or stop flow due to an air block.

The purpose of the 200AVC is to release air, particularly during initial filling of the water system, but also after filling when entrained air from the boiler or heat exchanger, must be vented to atmosphere from the air separator tank.

The 200A is equipped with a vacuum check to prevent air from re-entering the air separator.

Sizing Air/Vacuum Valves for Pipelines

General explanation of operation: APCO Air/Vacuum Valves open whenever the internal pressure of the pipeline approaches a negative value, allowing the water level in the valve to lower and the float to drop from the seat. Their function is to vent large volumes of air from pipelines when they are initially filled and to allow air to re-enter the lines to break a vacuum. On the typical engineers profile, the gradients are usually indicated. These can then be used for pipeline slopes for calculating the flow down the pipeline. A minimum valve size is established by finding the size for filling, which is usually less than the drainage flow. We use a 2 psi pressure differential for the filling flow, 5 psi for the drainage flows. Above 2 psi, the air flow out across the valve orifice becomes so great, it may cause two problems: 1] The valve may close prematurely due to turbulence, trapping an air pocket in the system; 2] When the valve closes, the abrupt cessation of flow may create substantial pressure rise and slam, which may damage the air valve or pipeline. The 5 psi differential for inflowing air represents a safe average for protecting the pipeline and gasketed joints from damage due to vacuum.

1. Calculate necessary valves independently for each high point line.
2. Consider more severe of the two gradients adjacent to each high point.
3. Determine maximum rate of flow in cubic feet per second which can occur in this gradient for both filling and draining of the line. Always be sure to take the highest possible rate of flow under either circumstance (filling or draining).

To calculate rate of flow:

If the line is being filled by pump:

$$\text{Rate of flow in c.f.s.} = \frac{\text{GPM of pump}}{449}$$

If the line is being drained by gravity:

$$\text{Rate of flow in c.f.s.} = 0.08666 \sqrt{SD^5}$$

Where S = Slope (in feet per foot of length)

D = Diameter of pipe (inches)

4. The valve to be installed at this high point must release or re-enter an amount of air in c.f.s. equal to the maximum possible flow of water in c.f.s. immediately adjacent to this now determined high point.
5. To economize in the size of valves selected, final step is to determine the maximum pressure differential which can be tolerated across the valve orifice consistent with the required flow of air in c.f.s. already determined.
6. To determine this maximum tolerable differential pressure, it is necessary to calculate if there is a risk of line collapse from vacuum. This condition is usually only present in thin-walled steel lines above 24". To calculate collapsing pressure for thin-walled, cylindrical pipe.

$$P = 12500000 \left(\frac{T}{D}\right)^3$$

Where P = Collapsing pressure (PSI)

T = Thickness of pipe (inches)

D = Diameter of pipe (inches)

Includes Safety Factor of 4

7. For draining and air flow in, use the maximum pressure differential calculated, or 5 psi, whichever is lower. Enter the graph with this differential (never greater than 5 psi) and the flow found during draining to select the appropriate valve to protect your line from collapse and water column separation due to vacuum.
8. For filling and air flow out, next enter the graph with the maximum rate at which the line can be filled, and use a 2 psi differential pressure. This valve size is sufficient to vent all air from the line before valve closure. This ensures maximum performance from the line.
9. Compare the sizes calculated in steps 7 & 8 - use whichever size is larger for the total protection of your system.
10. These valves should be installed on the high point with a shut-off valve below them.
11. The same procedure should be followed for each individual high point.
12. If the line lacks clearly defined high points, or they are separated by long stretches of uniform gradient, it is recommended that the proper valves be selected as explained above and duplicate installations be made at regular intervals of 1/4 to 1/2 mile at the engineer's discretion.

To Ensure Maximum Capacity from the Pipe Line

When a line is in operation, air pockets collect both at the high point and for a distance down stream from the high point. To release this air, install the APCO Air/Vacuum Valve along with a 2" - APCO No. 200A Air Release Valve at the high point and a second Air Release Valve a short distance downstream.

Sizing

Use APCO Slide Rule Air Valve Computer or APCO Apslide Software

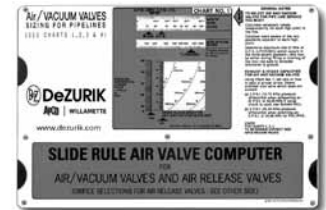

Performance Graph for Air/Vacuum Valve Air Inflow/Outflow Thru Valve in Standard Cubic Feet of Free Air Per Second, (SCFS)

Inflow

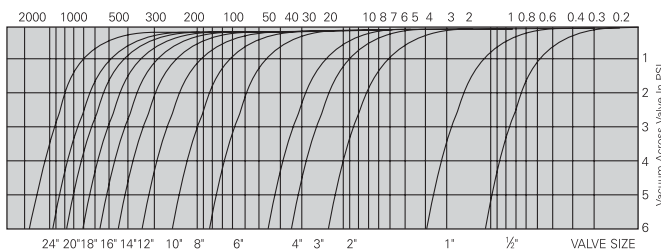

Curves shown are actual flow capacities at 14.7 psi barometric pressure and at 70 °f temperature based on actual test.

These figures are not merely flow capacities across the orifice, but flow capacities across the entire valve.

In the test set-up, air approach velocity is negligible, therefore, actual flow capacity exceeds the values shown on chart.

Tests Conducted By: Phillip Petroleum Company
Engineering Department — Test Division
Edmond Plant Feb. 2, 1961
Southern Research Institute
Birmingham, Alabama May 8, 1959

Outflow

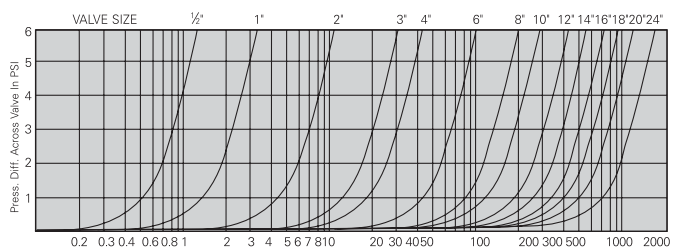

Sales and Service

For information about our worldwide locations, approvals, certifications and local representative:

Web Site: www.dezurik.com E-Mail: info@dezurik.com



250 Riverside Ave. N. Sartell, Minnesota 56377 • Phone: 320-259-2000 • Fax: 320-259-2227

DeZURIK, Inc. reserves the right to incorporate our latest design and material changes without notice or obligation. Design features, materials of construction and dimensional data, as described in this bulletin, are provided for your information only and should not be relied upon unless confirmed in writing by DeZURIK, Inc. Certified drawings are available upon request.