

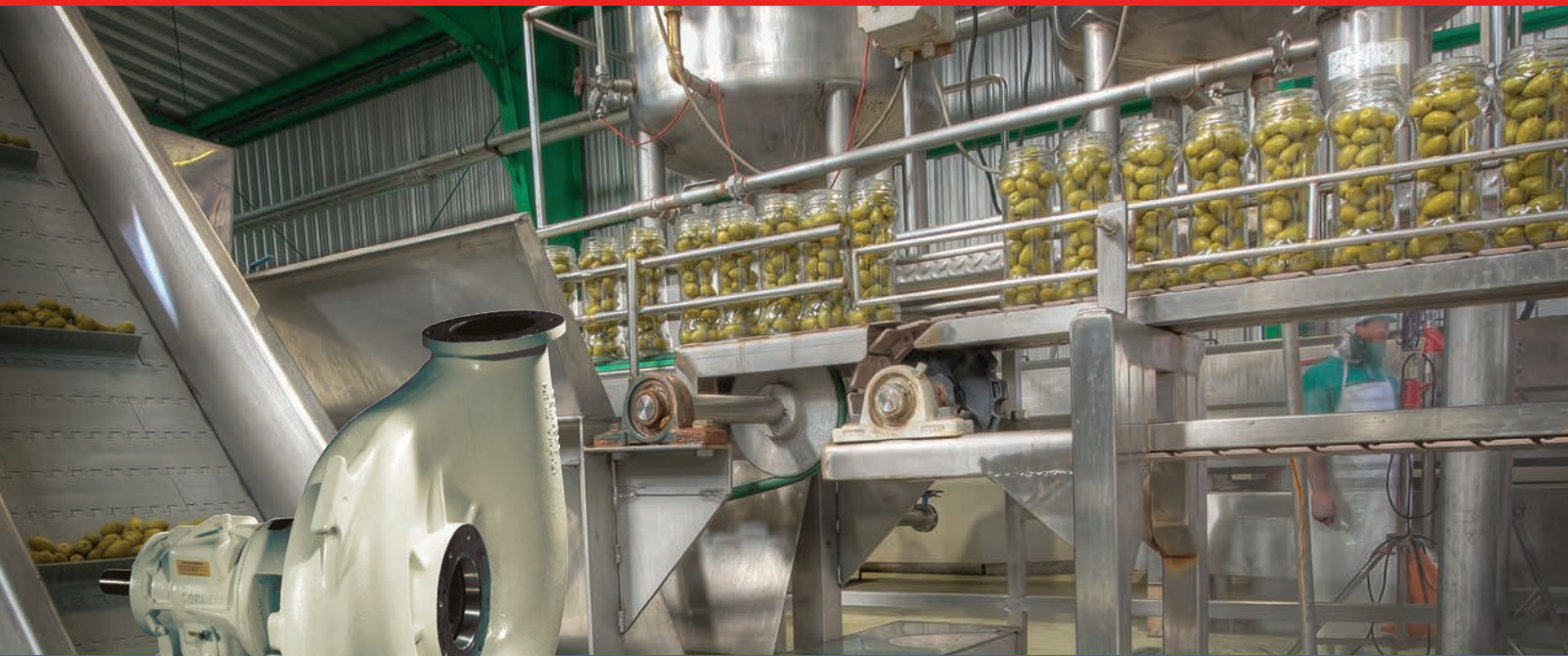

CORNELL PUMP COMPANY FOOD PROCESS



EFFICIENT BY DESIGN



FOOD PUMPS

Cornell Engineers understand the important role food handling pumps play in today's marketplace. Our innovative single port impeller configuration with unique offset volute* provides the end user with a food handling pump capable of transporting even the most delicate food products.

At Cornell, we've built our worldwide reputation on quality and reliability. Our centrifugal pumps are engineered and manufactured to provide continuous and trouble-free operation. As a matter of fact, many Cornell pumps sold in the 50's are still providing the same continuous and dependable service they did the day they were installed. No one is more committed to making your ownership a truly rewarding experience than Cornell.

INNOVATION

Many Cornell innovations have evolved from our commitment to the food processing marketplace and an ongoing effort to work with the industry in providing solutions for food handling applications.

Performance Focused Pump Design

Cornell's distinctive pump design allows food to pass through the pump and exit through the center of the discharge nozzle while minimizing contact with any pump surface. The single port impeller, a proven feature consisting of a large and rounded leading edge vane, was designed specifically for handling whole or processed foods. Together, these features significantly reduce product damage and abrasion, thus insuring product integrity.

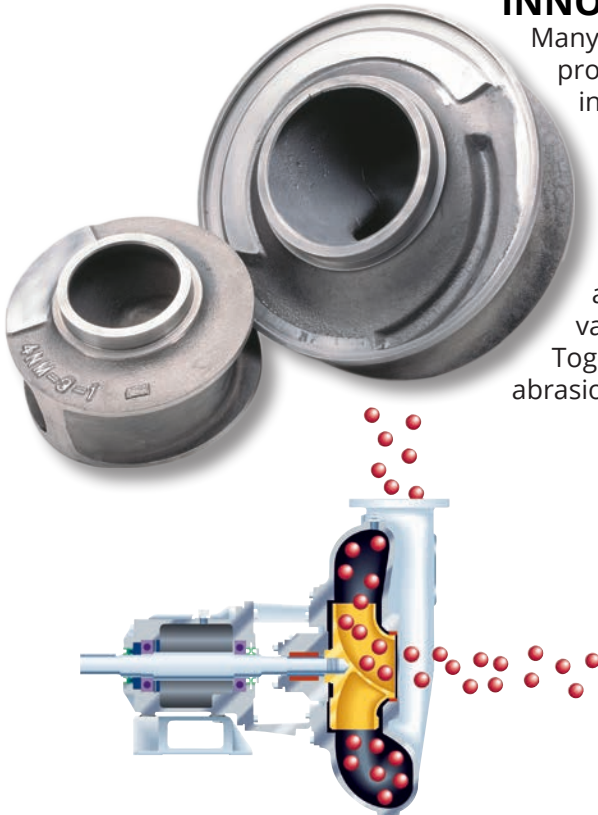

EFFICIENCY

In addition to a dependable pump system, today's food process systems must also be efficient and economical. As energy costs rise, conservation and efficient operation become critical issues for end-users striving to minimize expenses associated with energy consumption. Cornell pumps maintain superb hydraulic operating efficiencies and are coupled with energy efficient motors.

HYDRO-TRANSPORT FOOD PUMPS

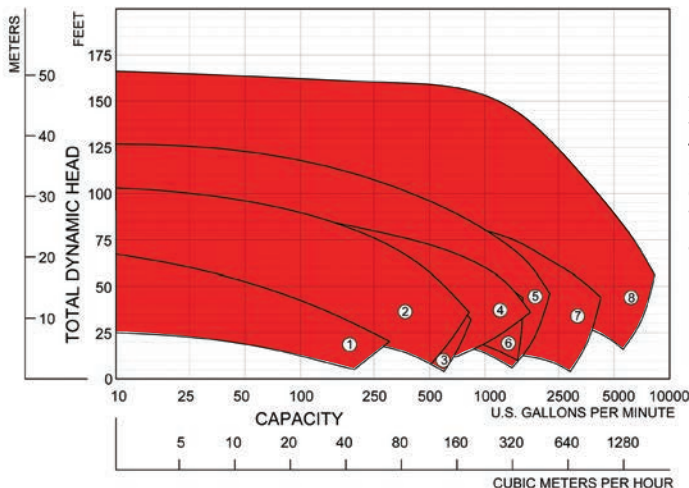

1. 3NLP
2. 4NMP
3. 4NMPP
4. 6NHP
5. 6NHPP
6. 8NHPP
7. 10NHPP
8. 12NHPP

QUALITY ASSURANCE

Cornell Pump Company proudly maintains its ISO 9001:2008 certification which validates that Cornell is in compliance with all necessary processes to meet customer requirements.

The elements associated with ISO 9001:2008 certification include such areas as contract review, design and development, production, purchasing, quality control and service.

THE BOTTOM LINE... CORNELL PUMPS COST LESS TO OPERATE.

* Cornell offset volute configuration is registered in the U.S. Patent and Trademark Office.

WASTE WATER

SOLIDS HANDLING PUMPS

With flow rates exceeding 38,000 GPM and heads to 800' TDH, Cornell is the industry leader for heavy-duty, efficient, low maintenance pumps. Cornell has incorporated many unique and innovative design features into our waste water line. These pumps are specifically designed to handle abrasive solids and large diameter materials in a multitude of waste water applications.



CHOPPER PUMPS

Cornell Chopper pumps are constructed of ductile iron with replaceable cutter bars of T1 tool steel (heat treated to a minimum 60 Rockwell C hardness) and are ideally suited for chopping solids. Standard construction includes a heat treated cast alloy steel impeller (min. 60 Rockwell hardness) and stainless steel shaft sleeve. Back-to-back angular contact ball thrust bearings and single ball radial bearings make for smooth operation. Each Chopper pump is fitted with a Type 2 tungsten carbide mechanical seal. TDH ranges from 30' to 200' with flows ranging from 0 - 1,500 GPM. The pumps are available in 4" and 6" discharge sizes.



DELTA STYLE PUMPS

Cornell's Delta style pump is designed to handle rags and stringy material. Two distinct vortices are created by the impeller which pass solids through the pump. The absence of sharp impeller edges prevents "hair pinning" or hang-up of stringy materials. Larger solids are effectively broken up by the comminuting action of the impeller vanes. Many of our enclosed impeller type pumps can be retrofitted with Delta style impellers.

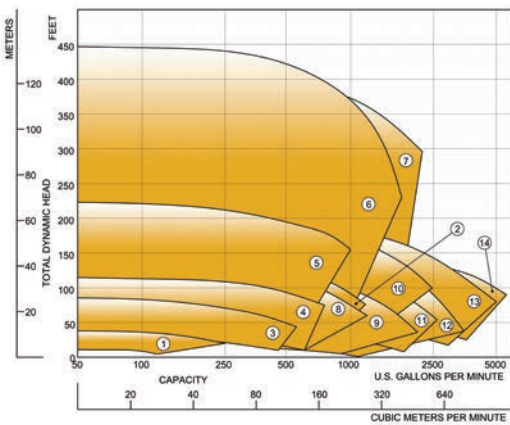
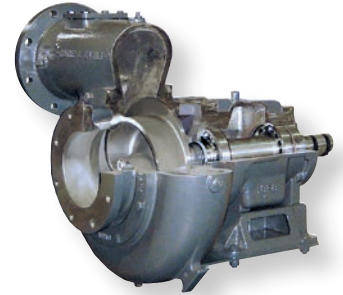

DELTA PUMP CURVES

- | | |
|----------|------------|
| 1. 3NLA | 9. 8NNDH |
| 2. 4NLDL | 10. 10NNDH |
| 3. 4NNDH | |
| 4. 4NHDL | |
| 5. 4NHM | |
| 6. 6NHDH | |
| 7. 6NHM | |
| 8. 6NNDH | |

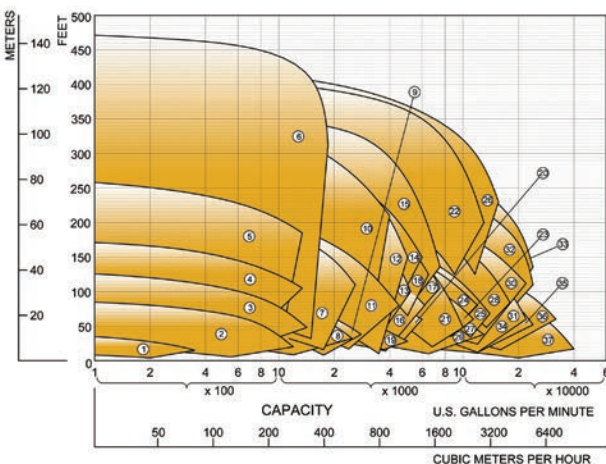

ENCLOSED IMPELLER PUMP CURVES

- | | | |
|------------|-------------|-------------|
| 1. 3NLT | 16. 10NHTB | 31. 18NHFL |
| 2. 4NNLT | 17. 10NHTBH | 32. 18NHF34 |
| 3. 4NNT | 18. 10NHTA | 33. 18NHG34 |
| 4. 4NHTA | 19. 12NHTL | 34. 20NHFL |
| 5. 4414T | 20. 12NHTM | 35. 20NHFL |
| 6. 4NHTB | 21. 12NNF | 36. 24NNG |
| 7. 6NHTA | 22. 12NHG28 | 37. 30NNT |
| 8. 6NNT | 23. 14NHG | |
| 9. 6NHT/TH | 24. 14NHGA | |
| 10. 6NHTB | 25. 14NHGH | |
| 11. 8NNT | 26. 14NHG28 | |
| 12. 8NHTA | 27. 16NHGH | |
| 13. 8NHHT | 28. 16NHG22 | |
| 14. 8NHTR | 29. 16NHG32 | |
| 15. 8NHGA | 30. 18NHG | |

HOT COOKING OIL

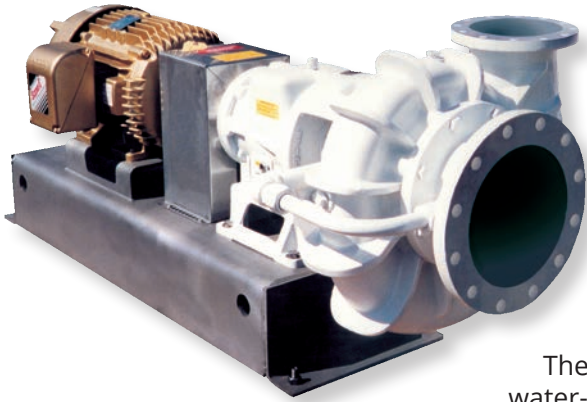

Enhanced vapor handling and improved sealing technology are central to Cornell's latest hot cooking oil pump innovations. When fresh product passes through a fryer, water tends to travel along the bottom of the fryer in a liquid phase at 392°F (200°C), until it reaches the pump suction where the action of the impeller breaks up the water into smaller droplets that flash into steam. Ordinarily, entrained steam would impair the pump's head and flow, but Cornell's innovative anti-cavitation system prevents this situation.

MECHANICAL SHAFT SEAL

The metal bellows mechanical shaft seal, with an optional water-cooled seat, can be used where temperature requirements reach up to 550° F. This proven shaft sealing method was developed over many years of field testing and is optimized to provide food processors with the most reliable and cost effective seal system in the marketplace. The metal bellows seal provides superior performance in extreme temperature processing services. The bellows leaf construction offers greater metal dependability and more uniform bellows compression.

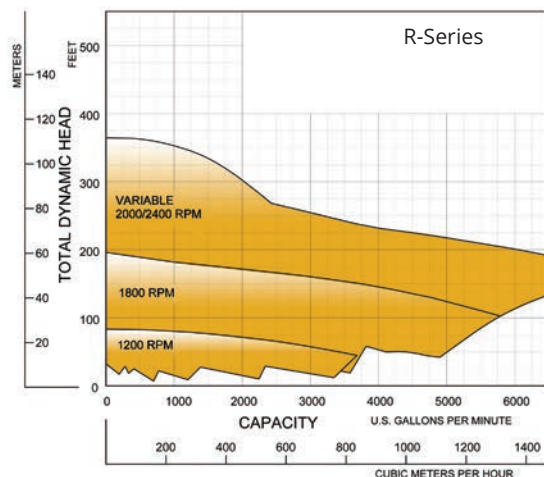
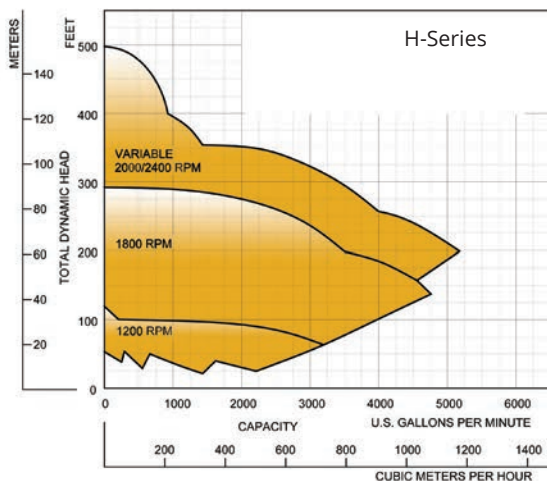
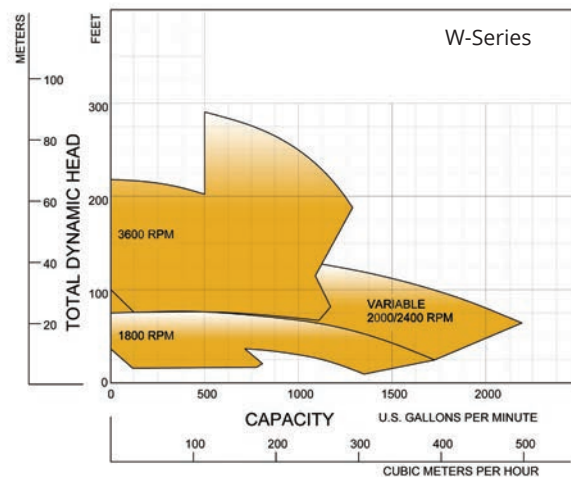
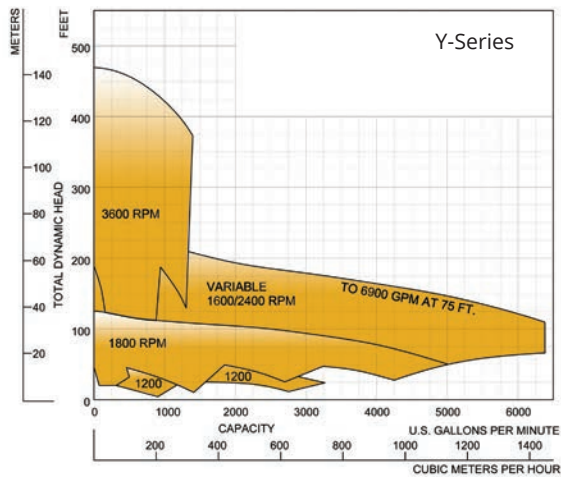

AVAILABLE OPTIONS

CYCLOSEAL®

The Cycloseal® system is a self-contained single mechanical seal upgrade for the standardized food grade packing feature. It **requires no external flushing** which is ideal for eliminating the water usage normally associated with mechanical seals. Cycloseal® uses stationary 'vanes' cast into the pump backplate to create pressure gradients that move solids away from the seal faces. As a result, the requirement for an external water flush line for abrasive service is avoided, and seal life is extended to at least three times the life of a standard seal. The Cycloseal® design is available in all food handling pumps except for hot oil pumps.

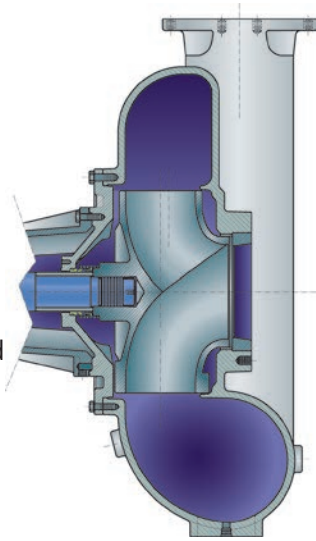

As a result, the requirement for an external water flush line for abrasive service is avoided, and seal life is extended to at least three times the life of a standard seal. The Cycloseal® design is available in all food handling pumps except for hot oil pumps.

DOUBLE VOLUTE DESIGN

The double volute system enables Cornell single-stage, end-suction centrifugal pumps to easily perform big volume and high pressure jobs. On single volute pumps, the increasing pressure acts against the impeller area and creates unbalanced radial forces. By contrast, the Double Volute System effectively balances these forces around the impeller to reduce shaft flexure and fatigue for longer seal life, bearing life, and shaft life.

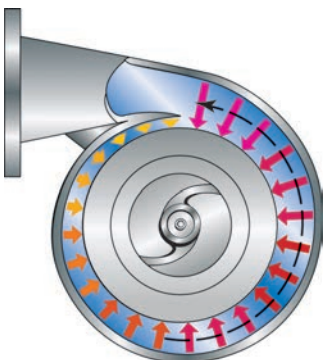

Single Volute

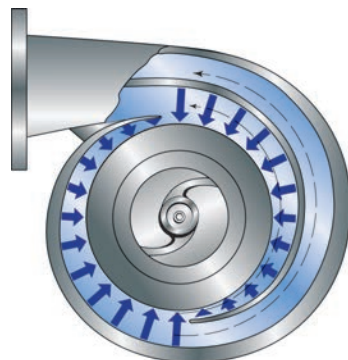

Double Volute

MOUNTING CONFIGURATIONS

Cornell's Modular Frame design allows for easy adaptability. Choose a pump, then pick the mounting configuration best suited to your application. Right hand and left hand rotation along with tangential or centerline discharges are available for most pumps.

CC Horizontal
Close Coupled

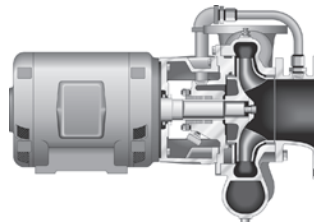

VC Vertical
Coupled

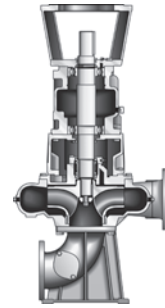

F Horizontal
Frame Mounted

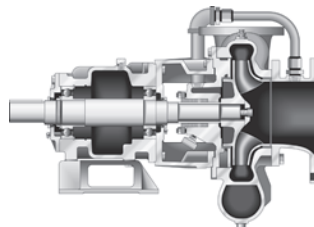

VM
Vertical
Close
Coupled

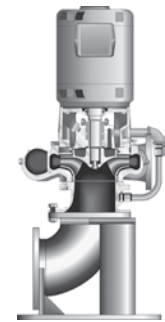

RUN-DRY™ OPTION

Run your pump dry without the use of expensive water systems and without mechanical seal damage. Cornell's Run-Dry™ system consists of an auxiliary gland which provides containment for an application-specific lubricant present at the inside diameter of the mechanical seal faces. This lubricant prevents dry running of the seal faces while priming, re-priming, and on standby. The Run-Dry™ gland is connected to a lubricant reservoir via inlet and outlet lines which are oriented tangentially to the pump shaft so that shaft rotation provides circulation and subsequent cooling of the lubricant.

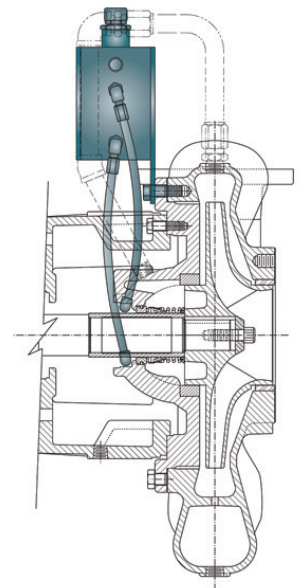

COMPLETE PUMPING SOLUTIONS

REFRIGERATION PUMPS

Cornell's liquid overfeed pumps have been used successfully in a variety of applications including cold storage, food processing, refrigeration, ice production and turbine inlet cooling. Cornell refrigerant pumps



are commonly employed in liquid overfeed and transfer pump applications utilizing anhydrous ammonia, aqueous ammonia and halocarbons such as R-22 and other approved refrigerants. Cornell also offers hermetic style refrigeration pumps which have operating

capabilities and dimensions similar to our standard CB pumps. The Arctic King HT series is perfect for stable operating systems that have minimal vapor entrainment or cavitation issues.

CUTTER PUMPS

The cutter pump was created in order to address the urgent need of reducing clogging due to ragging.



With the increased use of 'flushable' materials and extraneous cleaning products, the issue of clogging—leading to downtime, pump destruction, and pipe damage, has increased markedly. Useful in municipal, agricultural, and other markets, the cutters unique stationary

and rotating blade design allows material to pass through the impeller that would tend to clog a non-cutter pump.

STX SERIES

Cornell has redesigned our popular self-priming line to have the best efficiencies in the industry. Combined with our patented Cycloseal® back plate technology, the pump is durable, powerful, and energy efficient.



REDI-PRIME®

Cornell's Redi-Prime® pumps are designed with oversized suctions to provide more flow, reduced friction losses, and higher suction lift. The priming system was designed with the environment in mind. By using a positive sealing float box and a diaphragm vacuum pump, there is no water carry-over to contaminate the environment. With suction lifts of up to 28', heads to 800' and flow rates exceeding 20,000 GPM, most Cornell pumps can be readily fitted with the Redi-Prime® system.



HYDRAULIC SUBMERSIBLES

Cornell's DuraSub™ uses a heavy duty pump end and bearing frame for direct coupling to a **HYDRAULIC MOTOR**. The DuraSub™ has a modular design which allows standard Cornell pump ends to be used as a Hydraulic submersible pump.

- Available for most Cornell pump models
- Hydraulic motor driven
- Various adapter plates available for hydraulic motor fit
- Heavy duty shaft / bearing frame assembly and wet end construction
- Premium wet end efficiencies reduce horsepower requirements
- Heavy duty pumps ends for long service life and reliability



SUBMERSIBLE PUMPS

Cornell uses the same high efficiency pump-ends for our submersibles that have been proven time and time again in standard municipal applications. Coupled with the highest quality motors, Cornell's submersible product line provides the best possible value. The bottom line – Cornell Submersible Pumps cost less to operate.



GENERAL PURPOSE PROCESS

ENERGY EFFICIENCY

Cornell Pumps are designed to deliver best in class efficiency. Depending on operating hours, fuelant, and horsepower required, you can save \$3,000 per year (or more) in energy costs. Cornell manufactures more than 60 clear liquid and non-clog pumps that meet or exceed optimum efficiency standards for centrifugal pumps.

Select High Efficiency Pump Models:
8H-88% efficient
6RB-89% efficient
5RB-86% efficient
4RB-85% efficient



EXTERNAL HYDRAULIC BALANCE LINE

Cornell's external hydraulic balance line equalizes pressure between the impeller hub area and the pump suction to reduce axial loading acting on the impeller, shaft and bearings. The balance line also assists in moving sand and silt from the stuffing box to the low pressure area at the pump suction, reducing wear of the wetted parts.

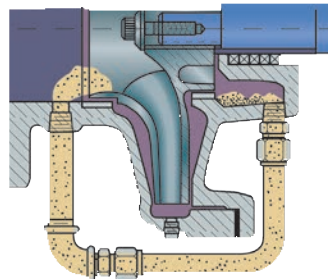

MATERIALS OF CONSTRUCTION

All Cornell process pumps are constructed with top quality materials. Our pumps are cast iron, bronze fitted or all iron construction. Standard features include balanced impellers, heavy-duty shafts, replaceable shaft sleeves, and replaceable wear rings. Optional materials are available for abrasive or caustic applications.



RESEARCH & DEVELOPMENT

Cornell Pump Company is known for its innovative designs at the leading edge of technology. We are constantly striving to improve and expand our range of highly engineered products using solid engineering practices plus aggressive research and development to maintain leadership in the food processing marketplace. Many unique and innovative 'firsts' have resulted from Cornell's willingness and ability to adapt to changing market requirements.





MARKET AND PRODUCT LINE

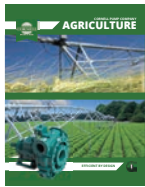

AGRICULTURAL

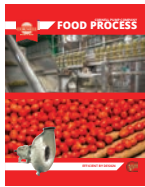

FOOD PROCESS



INDUSTRIAL



MINE DEWATERING



MUNICIPAL



REFRIGERATION



OIL & GAS



CHOPPER



CUTTER



EDGE™



HYDRAULIC SUBS



HYDRO TURBINE



IMMERSIBLE



MANURE



MP SERIES



MX SERIES



MX MINING



REDI-PRIME®



STX SERIES



SLURRY



SUBMERSIBLE



WATER TRANSFER

Cycloseal® and Redi-Prime® are Registered Trademarks of Cornell Pump Company.

Cornell pumps and products are the subject of one or more of the following U.S. and foreign patents: 3,207,485; 3,282,226; 3,295,456; 3,301,191; 3,630,637; 3,663,117; 3,743,437; 4,335,886; 4,523,900; 5,489,187; 5,591,001; 6,074,554; 6,036,434; 6,079,958; 6,309,169; 2,320,742; 96/8140; 319,837; 918,534; 1,224,969; 2,232,735; 701,979 and are the subject of pending U.S. and foreign patent applications.

CORNELLPUMP.COM
©2015 CORNELL PUMP COMPANY



Cornell Pump Company
Clackamas, Oregon, USA
P: +1 (503) 653-0330
F: +1 (503) 653-0338

AUTHORIZED CORNELL PUMP DISTRIBUTOR