



APCO CHECK VALVE GUIDE



**Rubber Flapper Swing
Check Valve**
Series 100



Slanting Disc Check Valve
Series 800



Automatic Control Check Valve
Series 8000



Silent Check Valves
Series 600 Globe Style
Series 300 Wafer Style

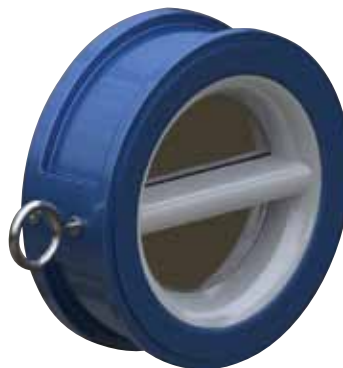

Double Door Check Valve
Series 9000



Cushioned Swing Check Valves
Series 6000
Series 6000B
Series 6100

Which Check Valve Should I Use?

Check valves are available in numerous types, styles and shapes. Generally a valve manufacturer builds only one type of check valve. DeZURIK/APCO builds seven types and twenty styles. Therefore, we offer the consulting engineer open, objective and unbiased information about a broad range of check valves and their proper selection and application. The purpose of this brochure is to collect and condense the many desirable features of the most common type checks into a single source. With a single source of information, we hope not only to simplify the design engineer's check valve selection, but more importantly, help make the selection accurate and compatible with the application intended.

Following are the basic types of check valves commonly used in the industry. Of these basic types, three types are available in several forms:

1. Swing Check Valve

- A. Single Disc
(Conventional Type)
- B. Dual Disc
(Split Discs)
- C. Single Disc
(Angle Seating)

2. Silent Check

- A. Poppet
(Center Guided)
- B. Disc
(Self Guiding)
- C. Ball
(Self Guiding)

3. Foot Check

- A. Swing
(Multi Disc)
- B. Lift
(Single Poppet)
- C. Single Ball

4. Slant Disc Check

- A. Single Disc
(Pivot Off-Center)

5. Flap Check

- A. Single Flap

6. Control Disc Check

- A. Single Disc
(Pivot Off-Center)

Although check valves look different, they each perform the same basic function which is flow through one direction and no flow (check) return. Check valves are commonly installed on the discharge side of the pump. The most important role of a check valve is to act as the automatic shut off valve when the pump stops to prevent draining of the system which the pump fills. However, each check valve has different shut-off characteristics. This brochure reviews these characteristics to help you select the best check valve for your project.

Pressure Surge (Water Hammer) can be greatly controlled by selecting the correct check valve, i.e. Silent Check Valves shut-off very fast ($\frac{1}{20}$ to $\frac{1}{10}$ second), making excellent surge protection devices when pumping short distances less than half a mile. Conversely, the Automatic Control Check Valve has extremely slow (and variable) speed shut-off; an excellent surge protection device when pumping long distances (more than half a mile).

No single check valve is all serving. For example, the Lift Check Poppet (Center Guided) would be excellent for clean fluid, but a poor selection for waste water because of the obstructive flow passages. Consider all aspects of your pumping application and refer to the comparison feature chart page 12 before making your selection.

DeZURIK/APCO Engineers have years of practical experience and knowledge to help finalize your check valve selection.

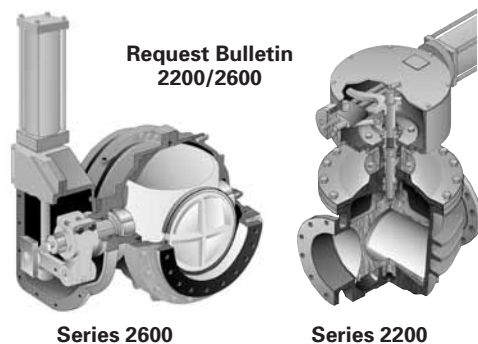

DeZURIK/APCO also makes other types of Control Valves:

APCO Willamette Series 2600 Ball Valves

APCO Willamette Series 2200 Cone Valves

These valves are suited for water and sewage pumping applications and are thoroughly explained in Bulletin 2200/2600. They are not included in this brochure.

The following pages briefly describes the various types of check valves with and without controlled opening and closing devices manufactured by DeZURIK/APCO. If you desire complete descriptive details about any of these check valves, please request the bulletin number listed below each product.

Check Valve Comparisons

Swing Check (Single Disc)

Swing Check closure is affected by gravity (weight of disc) and reverse flow. The pivot point of the Swing Check is outside the periphery of the disc and the greater the head, the greater the possibility that the fluid will flow back through the valve before the disc can be shut off.

Use caution applying this type of check valve where reverse flow velocities are high. (See APCO Cushioned Swing or Controlled Closing Check Valves)

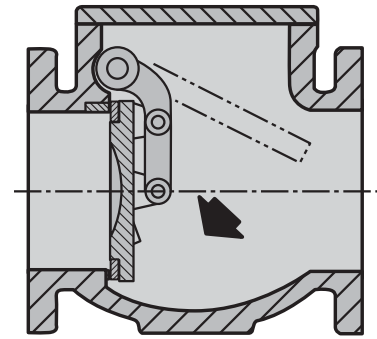

Conventional swing check valve disc closes through a long 70° to 90° arc. With reverse flow started, shut-off characteristics are greatly improved with addition of outside lever and spring, weight, air cushion, or oil cushion chamber.

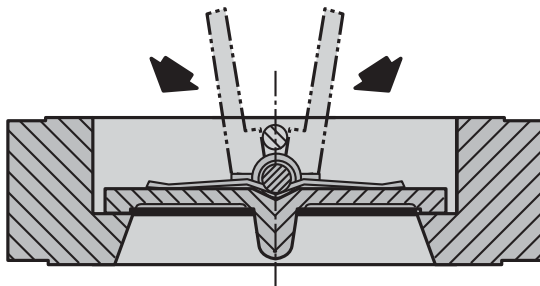

Typical double door valve with torsion spring which accelerates closing speed to minimize reverse flow and slamming.

Double Door Swing Check (Split Disc)

The Double Door Swing Check has the single disc split in two. By splitting the disc in two, the mass of the disc is greatly reduced. The torsion springs forcing the double discs to shut off with minimal flow reversal. This shut off characteristic greatly minimizes the slam potential as compared to the conventional swing check.

In double door checks the hinge pin is stationary and each disc swings freely when opening or closing. Multiple springs are used on larger sizes to compensate for heavier discs and to improve shut-off speed.

Rubber Flapper Check (Angle Seating)

The Rubber Flapper Check is another style of the Swing Check Valve which further attempts to improve the shut-off characteristics of the conventional Swing Check Valve.

The seating arrangement in this valve is the key to its success. The seat is on a 45° angle and therefore the flapper travels only 35° to reach full open position. With this short stroke, the valve is capable of very fast shut-off before reverse flow can develop and has non-slam characteristics. It is a full flow check valve.

The flapper is one piece Buna-N compression molded to specific durometers to satisfy tight shut-off at low pressures. The flapper is steel reinforced, but no metal is exposed to the media.

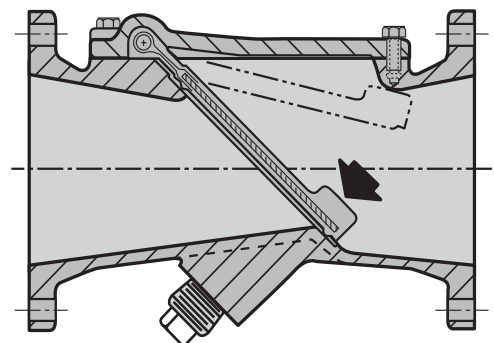

Rubber Flapper with Spring Return

For installations that experience rapid flow reversal the APCO 100SR (Spring Return) accelerates the closure of the disc prior to reverse flow taking place.

The APCO 100SR has been available since 1978.

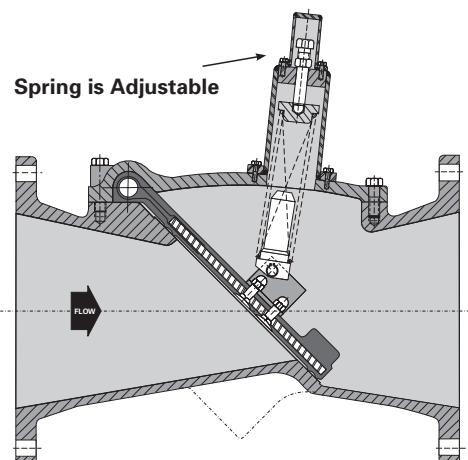

Check Valve Comparisons

Slanting Disc Check (Pivot Off Center)

Slanting Disc Check is a unique valve (Fig. 4). The main body is made of two pieces to allow a greatly enlarged flow area through the disc and seat section. The disc pivots off center with approximately 30% of the disc area above the pivot point to offer resistance against the 70% disc area below the pivot point. Hence, this type check has built in non-slam shut off characteristics.

The seating angle is 55°. The disc swings open through this 55° seat angle, traveling a short distance stopping at 15° off the horizontal. Hence, the disc travels only a short distance allowing minimal reverse flow and non-slam shut off.

This type valve is available with hydraulic controls and disc position indicators.

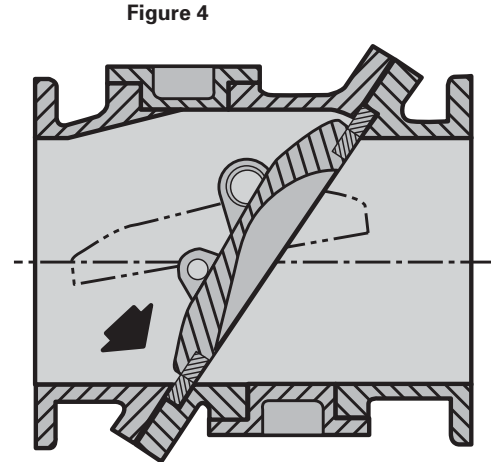

Silent Check (Center Guided)

Silent Check valves are available in two styles: Globe (Fig. 5) and Wafer (Fig. 6). Each operates identically. The center guided poppet is spring loaded normally closed. The once patented feature that results in silent shut-off, is the relation of the poppet to the seat when in the open position. This distance is approximately 1/4 of the valve size, i.e., a 4" valve has a 1" distance to shut off.

It is the short poppet travel distance coupled with the spring force that results in silent shut-off. The approximate time of shut-off is between 1/20 and 1/10 second. Silent Check valves are furnished with helical or conical springs. Both perform equally well – minimizing or greatly reducing any possibility of reverse flow (slam and minimizing the water hammer or pressure surges).

The Globe Style Silent Check is longer in laying length than the wafer style. The longer length allows for a greater flow through area than the wafer style.

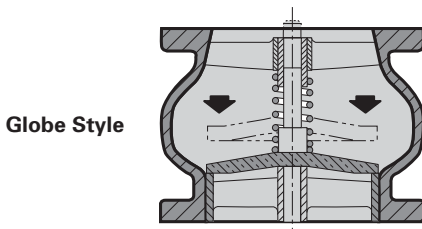

Figure 5

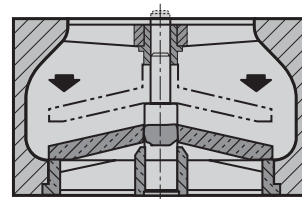

Figure 6

Globe style silent check valve has a spring-loaded disc that silently closes at zero flow velocity before reverse flow starts.

Wafer style silent check valve operates identical to the globe style in figure 5.

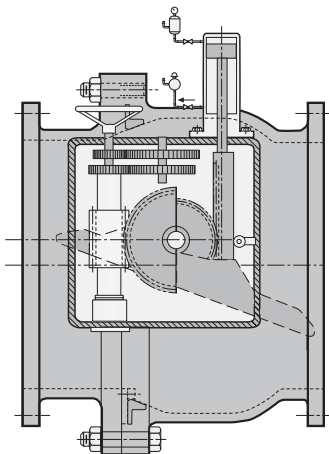

Figure 7

Automatic Control Check (Pivot Off Center)

All previously described check valves open and close when flow from the pump starts or stops. The opening and closing of the disc, poppet or flapper is uncontrolled.

The Automatic Control Check Valve, Fig. 7, is a unique check valve. It is recommended where pump flow control is essential to prevent pressure surges during pump start-up and shut-down. The valve (disc) is electrically controlled to permit remote operation from automatic pump stations. The valve functions as a shut-off valve, slowly opening after the pump starts and slowly closing when stopping the pump flow. Should loss of electrical power occur, the valve will automatically shut-off without any auxiliary power supply.

APCO Swing Check Valve Features

The Cushioned Swing Check Valve is a heavily constructed, full ported cushioned closure valve, constructed to meet A.W.W.A. standards. The cushioning device is an external cylinder which fills with air when the valve opens. When closing, the piston is driven downwards rapidly to compress the air trapped in the cylinder resulting in cushioned closing. The Cushioned Swing Check Valve is air cushioned for fast closing applications. For slow closing applications, oil control is recommended. All internals including the seat in the body can be removed through the bonnet without taking the valve out of the line.

Features

1. Full flow area
2. Outside lever and air cushion chamber
3. Free open-air cushion shut off
4. Free open-oil control shut off
5. Controlled opening and closing
6. Resilient seat or metal to metal
7. Rubber lining available
8. Low head loss
9. Heavy duty valve
10. Lever and cushion chamber installed on either side
11. Internals removable without taking valve out of line
12. Sizes 2" through 66"
13. Available in non-ANSI drilling for international application

Series 6000

- Air cushion
- Free open
- Fast closure



Series 6100

- Oil control
- Side mounted cushion



Series 6000B

- Oil control bottom buffer
- Free open, control close

Request Bulletin 6000

APCO Double Door Check Valve

Double Door Check Valves are extremely short in length, i.e. a 12" Double Door Check is $7\frac{1}{8}$ inches in length (a 12" conventional check is 28" in length) resulting in considerable material and labor savings. Therefore, this type check valve costs less per inch of size than most other types of check valves available. Although this valve is light in weight it is capable of heavy duty, continuous operation. The operational principle of the valve is the same as the ordinary outside lever and spring swing check valve, with the exception that the Double Door Check Disc is split in two through the center, thereby reducing the distance the disc must travel from open to close and reducing the possibility of slamming.

Features

1. Non-slam characteristics
2. Low head loss
3. Shortest laying length
4. Resilient or metal to metal seating
5. Can be installed vertically or horizontally
6. Plain flanges or lug style available
7. Rated up to 2500# class
8. Face to face dimensions to API 594 standards
9. Sizes 2" through 72"
10. FM approved & UL listed on some sizes
11. Available in non-ANSI drilling for international application



Wafer Style



Lug Style

Series 9000



Request Bulletin 9000

APCO Rubber Flapper Swing Check Valve

The Rubber Flapper Swing Check is uniquely simple in design. It has one moving part and the flapper does not pivot on a hinge pin, rather it flexes to open. This check valve is non-slamming in design because the flapper only travels 35° to reach the 45° seat. Since the flapper is spring loaded (due to resiliency) it usually closes before flow reversal or near zero velocity. The Rubber Flapper Check is virtually maintenance free. The flapper has been flex tested equivalent to 20 years of field service without fatigue. The Rubber Flapper Check was flow tested at Colorado State University and the test report is available.

Features

1. Non slam characteristics
2. Tight shut off at low pressure (less than 5 psi)
3. For buried service
4. Resilient seat standard
5. Full flow area
6. For sewage, water, oil, sludge, slurry or chemical service
7. Easily rubber lined, 100% encapsulation
8. No pins or bushing to wear out
9. Low head loss
10. Hold open device available for backflushing
11. Flapper can be replaced without removing valve from the line
12. Flow control device available
13. Proximity switch for remote control
14. Sizes 2" through 48"
15. Rated 125# class - Higher Pressure class available
16. Ductile iron construction standard
17. Available in non-ANSI drilling for international applications
18. Model 100SR (Spring Return) available for installations with rapid reverse flow.

Series 100

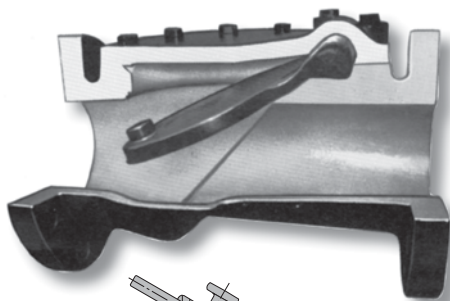
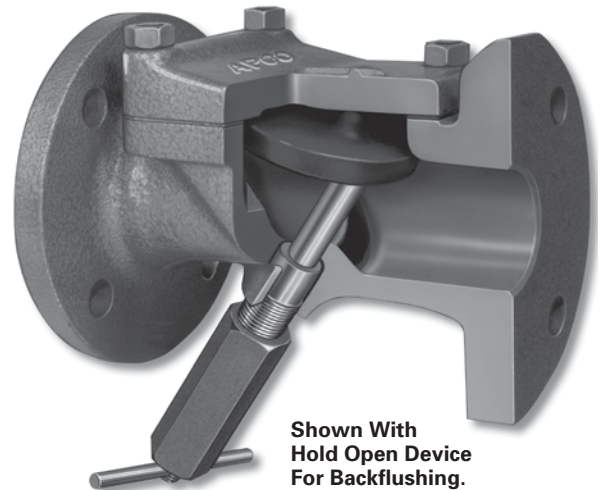
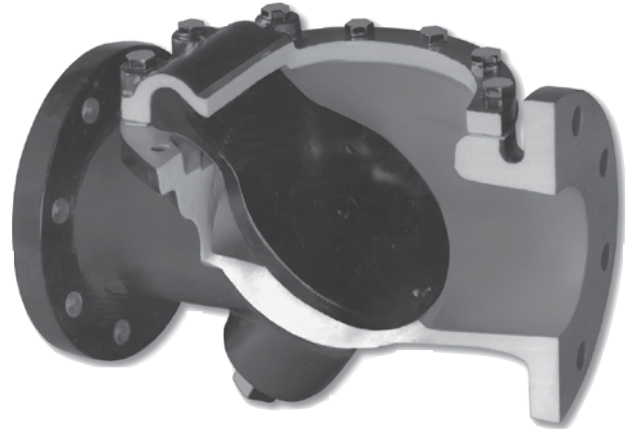

Flow Control Device

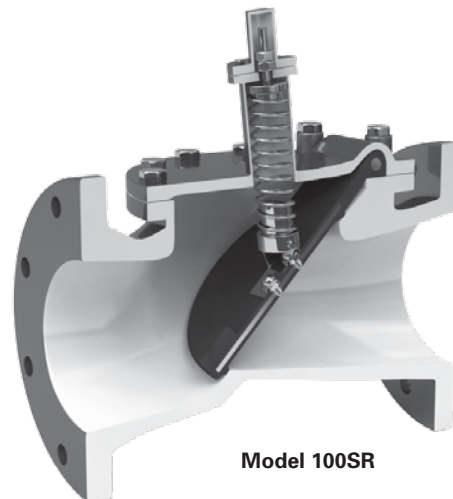
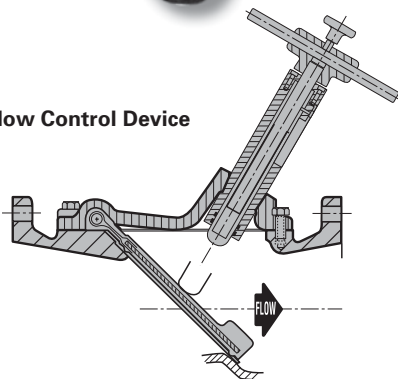

Request Bulletin 100

APCO Slanting Disc Check Valve

The Slanting Disc Check Valve is the most reliable swing type check valve available today. The pivot point of the disc is off center which sets it apart from other swing checks. The offset pivot point is unique and is one reason for the non-slam characteristics of the valve. The disc area above the pivot point counteracts the disc area below the pivot point, therefore, when the disc closes it should not slam. The split body design creates a 42% greater area through the disc section than the equivalent pipe area, hence, it has the lowest head loss compared to any other swing type checks.

Features

1. Non-slamming in design
2. Hydraulic disc controllers
3. Extremely heavy-duty, long life valve
4. Sizes 3" through 78"
5. Disc position indicator
6. Lowest head loss
7. Long laying length
8. Control opening and closing (800T)
9. Water hammer control without power activation
10. Free open-control closing (800B)
11. Must be removed from line to replace internals
12. Available in non-ANSI drilling for international application



800B
Bottom Mounted Buffer
Free Open-Control Closing

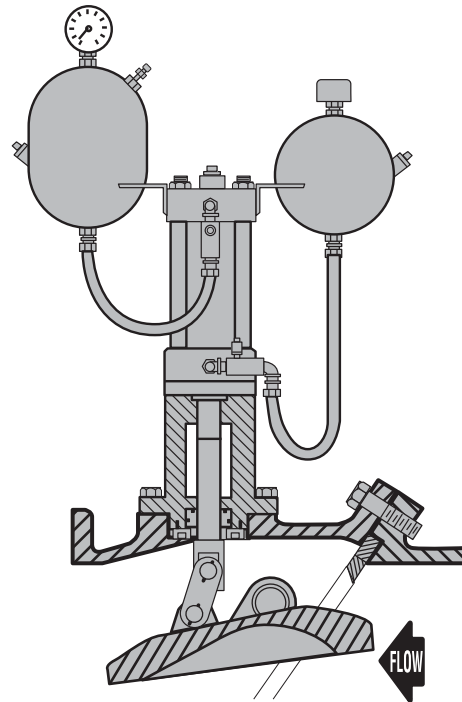
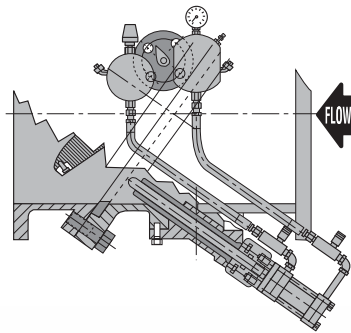

800T
Top Mounted Dashpot Controls
Opening & Closing

Request Bulletin 800

APCO Automatic Control Check Valve

The Automatic Control Check Valve is not a conventional type check valve. It is four valves in one. This automatic check is suitable where Pump Discharge Control is essential due to high velocities or on pipelines exceeding a mile in length. This valve is electric motor controlled. The valve can be directed from a remote control center automatically. The four valve features are: (1) shut off valve, (2) throttle flow valve, (3) controlled closing check valve, (4) drain valve. During operation, should power failure occur, the valve will automatically shut off at a controlled rate. There is no need for auxiliary power due to a unique slip gear arrangement and a built-in hydraulic system. The two piece body design creates full flow area through the valve and allows seat replacement in the field without removing the main valve from the line.

Features

1. Full flow globe style body
2. Disc contained in the body (disc does not enter pipeline)
3. Resilient seat and drop tight shut off
4. Seat replaceable without taking the complete valve out of the line
5. Positive disc stop prevents over travel
6. Electric motor operated for remote control
7. Built in hydraulic system
8. Fail-safe closure on power outage
9. Manual override
10. Adjustable open and close time
11. Best for surge control
12. Sizes 6" through 48"
13. Available in non-ANSI drilling for international application

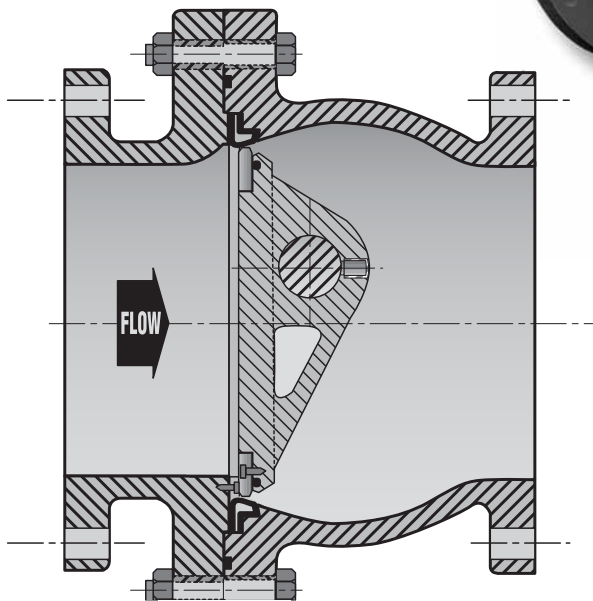
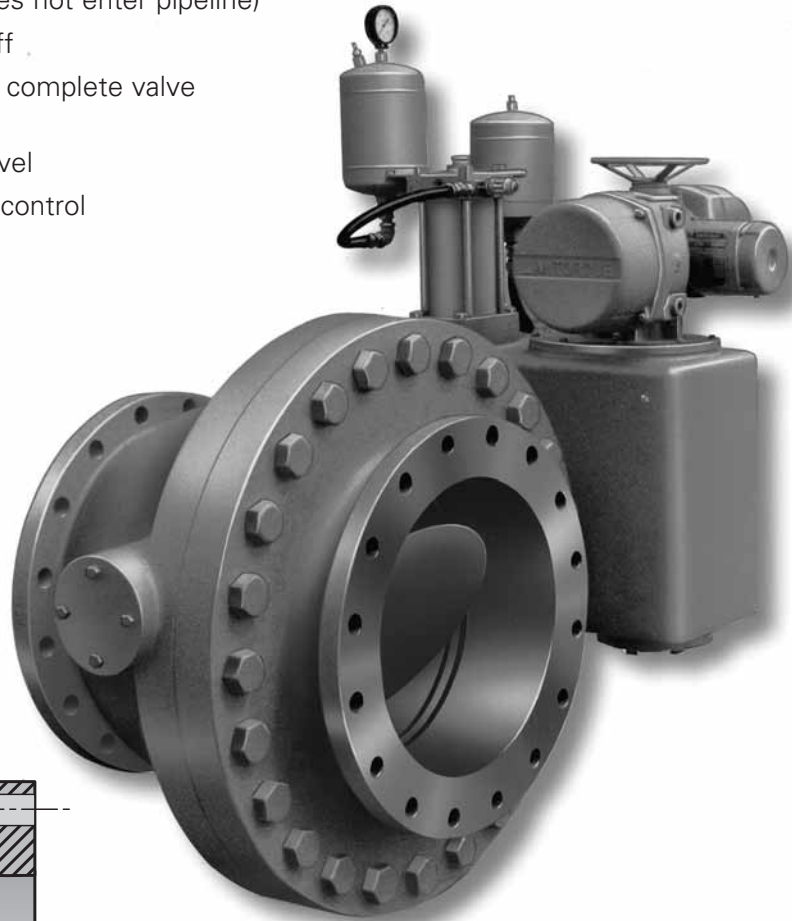

**Pump Discharge Control
Series 8000**

Request Bulletin 8000

APCO Silent Check Valves

The Wafer Style Silent Check Valve utilizes the same features as the Globe Style Silent Check within a compact wafer style body. Wafer Style Silent Checks are commonly specified for use in the H.V.A.C. field where silent operation is essential. They are not generally used in the municipal field because of their higher head loss. Use Wafer Style Silent Check where space savings in the pump house is the primary concern.

The globe style is the most popular. Silent Check Valves are fast closing. This type of check valve can be installed in any position, flow up or flow down. APCO Silent Checks in globe design minimize head loss.

Wafer Style Series 300

Features

1. Silent shut off
2. Short face to face
3. One valve for 125# or 250# mounting (up to 6" size)
4. Easy removal from the line
5. Higher head loss than globe style
6. Lowest cost
7. Install in any position
8. Resilient seating available
9. FM approved (some sizes)
10. Sizes 1" through 10"
11. Must be removed from line to replace internals
12. Available in non-ANSI drilling for international application

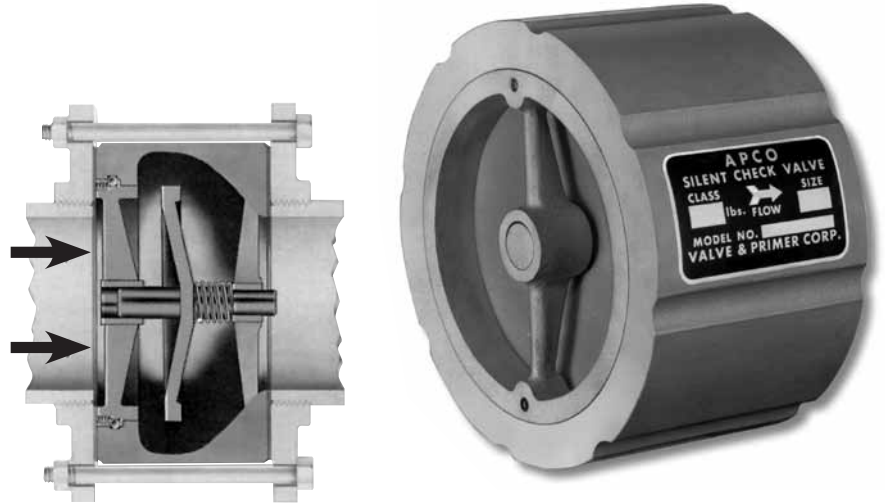

Globe Style Series 600

Features

1. Silent shut off
2. Integral flanges
3. Lower head loss than wafer style
4. More expensive than wafer style
5. Install in any position
6. Resilient seating available
7. FM approved (some sizes)
8. Sizes 3" through 42"
9. Must be removed from line to replace internals
10. Less turbulent flow condition
11. Available in non-ANSI drilling for international application

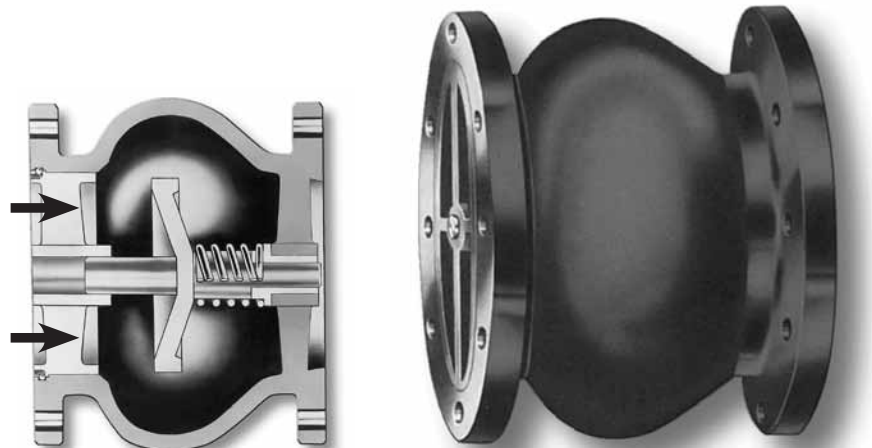

Request Bulletin 640

Dynamic Performance Of Check Valves

The head (pressure) rise in a pipe due to an incremental change in velocity is calculated using the following equation:

H = transient head (pressure) rise, ft (m)

a = wave speed, ft/s (m/sec)

V = change in velocity, ft/sec (m/sec)

g = gravity, 32.2 ft/sec² (9.81 m/sec²)

$$\Delta H = a \frac{\Delta V}{g} \quad \text{equation 1}$$

The transient head rise is directly proportional to the wave speed (equation 1). Wave speed is a parameter that must be accurately evaluated for each pumping system. After a sudden change in velocity, a pressure wave travels between two arbitrary points in a pipe in the time it takes the excess fluid entering the system at the initial velocity to enter the pipe section and come to rest. The pressure wave can travel at a relatively slow speed or it can travel very quickly. The transient pressure rise can be affected by the closing characteristics of the check valve.

So then, basically there is concern with the actual pressure rise in a piping system as it relates to the DYNAMIC PERFORMANCE of a check valve. The closure speed of different types of check valves is a function of the following:

- | | |
|---|---------------------------------|
| 1. Weight of the disc | 4. The valve orientation |
| 2. The rotational moment of inertia of the disc | 5. If the disc is spring loaded |
| 3. The distance that the disc must travel from fully open to fully closed | 6. Axis of rotation |

The transient pressure rise generated at valve closure is a function of how fast the valve disc closes and how fast the flow in the system reverses. The speed that the flow in the system reverses depends on numerous factors, some of which are:

- | | |
|------------------------------------|--|
| 1. The number of pumps | 5. The presence of surge protection devices such as air chambers and surge tanks |
| 2. The specific speed of the pumps | 6. Rotational inertia of the pumps |
| 3. The pipe length | 7. Surge wave speed (celerity) |
| 4. Profile and elevation changes | |

It is best to have the piping system in question simulated using a computer transient program to determine the maximum deceleration of the fluid in the system without the check valve installed. If it is determined that there is a slow deceleration in the system, then a check valve should close before any significant flow reversal occurs. Transient pressures generated by a check valve at closure will be minimal. For such a system the dynamic response of the valve is not important and any type of check valve would close without slamming. On the other hand, systems that generate a high deceleration at pump shutdown may induce significant reverse velocity before the check valve closes. The disc will slam shut, causing a pressure transient. For such systems, the valve selection process should consider the dynamics of the valve as well as the dynamics of the system.

The incorrect selection of check valves has been a source of unwanted pressure rise in pipeline systems. The situation can be exacerbated if a Surge tank (pressure vessel) is located in close proximity to the pump discharge. Field experience has proven that the APCO Slanting Disc Check Valve with a Bottom Mounted Buffer provides excellent performance in these instances.

The graph on the following page illustrates the dynamic performance of three types of APCO check valves: the Slanting Disc Check Valve, the Rubber Flapper Swing Check Valve and the APCO Silent Check Valve.

The graph is a plot of velocity reduction (reverse velocity) through each style APCO check valve as they relate to system deceleration. The system deceleration is defined as the rate at which the flow slows to zero once the system pump stops. When there is an increase in the system deceleration there will be an increase in the velocity reduction (reverse velocity) with the end result being a rise in system pressure when the check valve closes. So then, it makes sense to use a check valve that has superior closing characteristics (dynamic performance) to minimize the pressure rise when your pumping system shuts down.

The graph to the right is a typical example of a transient recording showing a pressure rise due to a check valve closure.

Added Benefit: The APCO Slanting Disc Check Valve and the APCO Rubber Flapper Swing Check Valve both have outstanding flow characteristics. They are extremely energy efficient when compared with other styles of check valves. (Please see the Pressure Loss comparison chart on the last page of this bulletin, or use the APCOST [Domestic or International version] computer software to determine energy efficiencies for these style check valves.) These two APCO Check Valves will give you superior closing characteristics as well as superior flow characteristics. Excellent flow and excellent closure.

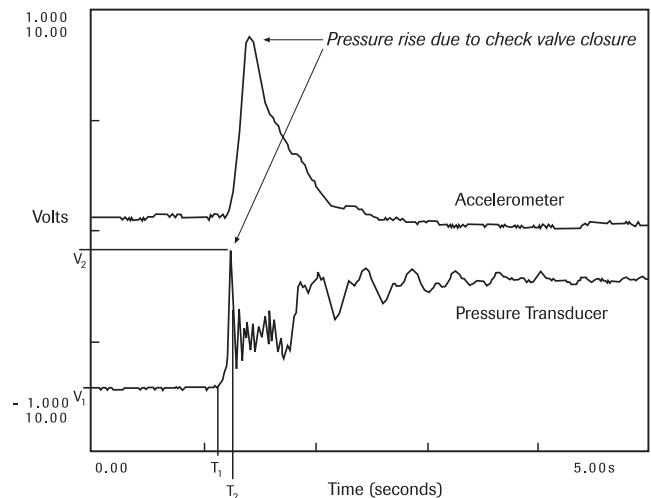

Example of a typical transient recording

